

FRAME SET IN NON-ROADWAY LOCATION
N.T.S.

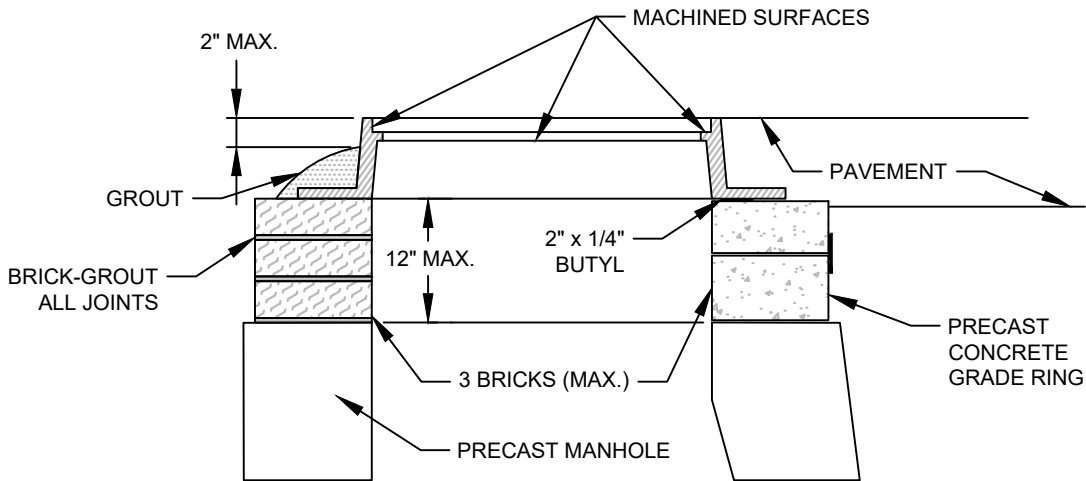

FRAME SET IN ROADWAY LOCATION
N.T.S.

NOTE:

1. WATERTIGHT FRAME & COVER REQUIRED IN FLOODPLAIN OR WHEN SPECIFIED ON PLANS
2. "MSD OF BUNCOMBE COUNTY" TO APPEAR ON COVERS ONLY WHEN THE SEWER SYSTEM IS TO BE MAINTAINED BY MSD

STANDARD DETAIL	
Metropolitan Sewerage District of Buncombe County, North Carolina	
WATERTIGHT MANHOLE FRAME & COVER	
DATE APPROVED: MARCH 2017	2.11 - 08.2