

FY 2025

**CONTRACT FOR THE RESTORATION OF NON-CITY OF
ASHEVILLE ROAD RIGHTS-OF-WAY
FOLLOWING MSD WASTEWATER COLLECTION SYSTEM
MAINTENANCE**

Project No. 2002101

**METROPOLITAN SEWERAGE DISTRICT
OF
BUNCOMBE COUNTY, NORTH CAROLINA**

**FY 2025 CONTRACT FOR THE RESTORATION OF
NON-CITY OF ASHEVILLE ROAD RIGHTS-OF-WAY FOLLOWING MSD
WASTEWATER COLLECTION SYSTEM MAINTENANCE
PROJECT NO. 2002101**

OWNER: Metropolitan Sewerage District
of Buncombe County, NC
2028 Riverside Drive
Asheville, NC 28804
Phone: (828) 254-9646
Fax: (828) 232-5537

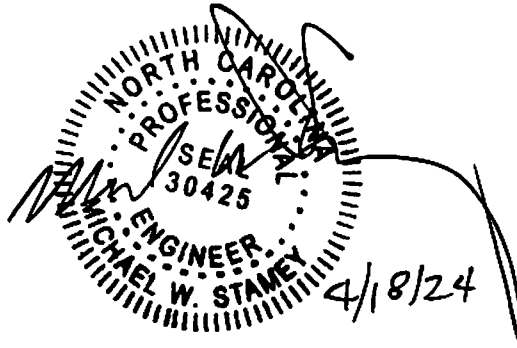

CONTRACTOR: _____

TABLE OF CONTENTS

SECTION

DEFINITION

I	Advertisement for Bids
II	ISO14001 Information Sheet
III	Instructions to Bidders
IV	General Conditions
V	Special Conditions
VI	Specifications and Details
VII	Minority Business Information and Forms
VIII	Non-Collusion Affidavit
IX	Measurement and Payment / Bid Schedule
X	Proposal
XI	Bidder's Reference Page
XII	Bid Bond
XIII	Notice of Award
XIV	Agreement
XV	Performance and Payment Bonds
XVI	Certificate of Insurance
XVII	Notice to Proceed
XVIII	Application for Payment / Affidavit of Payment of Claims / Sales Tax Certification

ADVERTISEMENT FOR BIDS

Formal sealed bids will be opened by the Metropolitan Sewerage District (DISTRICT) of Buncombe County, North Carolina, 2028 Riverside Drive in Asheville, North Carolina, 2nd floor conference room, at **10:30 AM** (local time), **Friday, May 17, 2024**, for the project described as follows:

FY 2025 Contract for the Restoration of Non-City of Asheville Road Rights-of-Way Following MSD Wastewater Collection System Maintenance, Project No. 2002101

The work to be done generally consists of furnishing all services, supplies, materials and equipment, and necessary labor to repair and repave those portions of Non-City of Asheville road rights-of-way disturbed by maintenance operations of the DISTRICT. Said work must be done in accordance with specifications maintained by the DISTRICT.

All work shall be performed by a licensed CONTRACTOR as provided in Chapter 87 of the General Statutes of the State of North Carolina holding either a Highway or Unclassified license. Said CONTRACTOR shall meet all applicable requirements for paving work in NCDOT roadways and/or the municipality where work is being performed.

A pre-bid meeting is scheduled for Friday, May 10, 2024, at 10:30 AM. This meeting is not mandatory, but highly recommended.

Proposals will include unit prices for work in accordance with the units set forth on the Bid Sheet. Proposals submitted by mail shall be marked "SEALED BID" and sent to the Metropolitan Sewerage District of Buncombe County, North Carolina, 2028 Riverside Drive, Asheville, NC 28804. Attention: Denise Moore. Proposals may not be withdrawn for a period of sixty (60) days after May 17, 2024.

Complete proposal package may be **examined** at the DISTRICT website: www.msdbc.org/projects/adsforbids.php

Copies of the proposal package may be obtained from Denise Moore by calling 828-225-8277 or email: denisem@msdbc.org

Proposals must be submitted by and signed by an authorized representative of the CONTRACTOR. Each Bidder must comply with DISTRICT's Guidelines for Recruitment and Selection of Minority Business. Proposals should demonstrate evidence of efforts to comply.

It is anticipated that the DISTRICT's total restoration work in this contract will be approximately \$509,000.00 for a one year period.

Each bid shall be accompanied by a deposit with the Metropolitan Sewerage District of Buncombe County of cash, or a cashier's check, or a certified check on some bank or trust company insured by the Federal Deposit Insurance Corporation in an amount equal to not less than five percent (5%) of the bid amount. In lieu of making the cash deposit as above described, a satisfactory Bid Bond in the amount of 5% of the total bid, executed by a corporate surety licensed under the laws of North Carolina to execute such bonds, shall be submitted with each bid, conditioned that the surety will upon demand forthwith make payment to the obligee upon said bond if the bidder fails to execute the contract in accordance with the bid bond. This deposit shall be retained if the successful bidder fails to execute the contract within ten (10) days after the award of bid or fails to give satisfactory surety as required in North Carolina General Statute Section 143-129.

The successful bidder will be required to furnish a Performance Bond and a Payment Bond in the amount of one hundred percent (100%) of the contract amount. Those bonds shall meet the requirements of North Carolina General Statute Section 143-129 and of Article 3 of Chapter 44A of the North Carolina General Statute.

The Metropolitan Sewerage District is proud to be an ISO-14001 Facility. All vendors who perform work on DISTRICT's property or as a Contractor of the DISTRICT are required to read the DISTRICT's Environmental Management System Brochure and acknowledge their understanding and acceptance of this information by signing the Environmental Health and Safety Training Form.

This contract shall be awarded to the lowest responsive, responsible bidder, taking into consideration quality, performance and time of delivery. The DISTRICT reserves the right to reject any and all bids, including, without limitation, the right to reject any or all non-conforming, non-responsive, unbalanced or conditional bids; bidders not pre-qualified by the DISTRICT, and to reject the bid of any bidder if DISTRICT believes that it would not be in the best interest of the DISTRICT to make an award to that bidder. DISTRICT also reserves the right to waive informalities.

The Metropolitan Sewerage District
of Buncombe County, North Carolina

Thomas E. Hartye, P.E.
General Manager



International
Organization for
Standardization

**Metropolitan Sewerage District
Environmental, Safety and Health**

MSD ISO 14001 Program



1. Purpose.

The Metropolitan Sewerage District of Buncombe County, North Carolina (MSD) is committed to environmental quality through ongoing continual improvement with conformance to the ISO14001 standard.

2. Scope.

MSD is committed to environmental awareness with all vendors and contractors who work for or on our behalf. We strive to outreach with our vendors and contractors to promote continual improvement and teambuilding.

3. MSD Environmental Policy

MSD is committed to ensuring environmental quality by:

- Monitoring our processes and operations for continual improvements.
- Setting and reviewing environmental objectives and targets for pollution prevention.
- Dedicating our organization to complying with applicable Federal, State and Local regulations.

4. Vendor / Contractor ISO14001 Environmental Conformance

- Knowledge of MSD ISO14001 Program and Environmental Policy
- Compliance with applicable Federal, State, Local rules and regulations
- If applicable, follow MSD standard operating procedures
- Promote Pollution Prevention at all times
- Recycle waste debris when possible
- Be aware of Emergency Response Procedures

5. Pollution Prevention Strategies

<p><u>Materials Management</u></p> <ul style="list-style-type: none"> √ Sand, dirt must be contained to prevent entering storm drains. √ Apply water to control dust √ Check dumpsters for leaks √ Label all hazardous materials and hazardous wastes in accordance with local, State and Federal regs. √ Fuel storage containers must be double walled or have secondary containment √ Dispose of hazardous waste correctly <p><u>Spill Prevention and Control</u></p> <ul style="list-style-type: none"> √ Report hazardous materials spills to owner immediately √ Keep spill cleanup materials available on-site and contain spills immediately <p><u>Equipment Maintenance and Cleaning</u></p> <ul style="list-style-type: none"> √ Inspect vehicles and equipment for leaks and repair promptly √ Do not clean vehicles at job site <p><u>Earthwork</u></p> <ul style="list-style-type: none"> √ Keep all excavated soil on the site where it is least likely to collect in the street. 	<ul style="list-style-type: none"> √ Use erosion control measures to minimize flow of silt off-site <p><u>Dewatering Operations</u></p> <ul style="list-style-type: none"> √ Water must be filtered / cleaned prior to entering into storm sewer. √ In areas of known contamination, testing is required prior to discharge of groundwater. Contaminated groundwater must be taken off site. <p><u>Saw Cutting / Concrete Waste Management</u></p> <ul style="list-style-type: none"> √ Cover or barricade storm drains when saw cutting to keep slurry out of storm sewer √ Collect slurry and dispose in concrete washout area √ Remove slurry immediately if it enters a catch basin √ Wash out concrete trucks off site or in pit / designated area. Allow water in pit to evaporate. <p><u>Painting</u></p> <ul style="list-style-type: none"> √ Never rinse paint brushes into street gutters or storm sewer √ Dispose of oil based paints / unusable thinner as hazardous waste
-------------------------------------------------------------------------------------------------------------------------------------------------------------------------------------------------------------------------------------------------------------------------------------------------------------------------------------------------------------------------------------------------------------------------------------------------------------------------------------------------------------------------------------------------------------------------------------------------------------------------------------------------------------------------------------------------------------------------------------------------------------------------------------------------------------------------------------------------------------------------------------------------------------------------------------------------------------------------------------------------------------------------------------------------------------------------------------------------------------------------------------------------------	----------------------------------------------------------------------------------------------------------------------------------------------------------------------------------------------------------------------------------------------------------------------------------------------------------------------------------------------------------------------------------------------------------------------------------------------------------------------------------------------------------------------------------------------------------------------------------------------------------------------------------------------------------------------------------------------------------------------------------------------------------------------------------------------------------------------------------------------------------------------------------------------------------------------------------------------------------------------------------------------------------------------------------------------------------------------------------------------------------------------

INDEX

<u>ARTICLE</u>	<u>DESCRIPTION</u>	<u>PAGE</u>
I	Preparation of Bids	2
II	Filing of Proposals	3
III	Opening of Proposals	4
IV	Withdrawal or Revision of Bids	5
V	Addenda and Interpretations	5
VI	Discrepancy in Bids	5
VII	Qualifications of Bidders	5
VIII	Bid Security	6
IX	Responsibilities of Bidders	6
X	Collusive Agreements	7
XI	Taxes	7
XII	Comparison of Bids	7
XIII	Award of Contract	8
XIV	Commencement of Work	8
XV	Damages for Failure to Execute Contract	8
XVI	Equal Employment Opportunity	8
XVII	Wages and Salaries	8

Section III - Instructions To Bidders

ARTICLE I PREPARATION OF BIDS:

All Bids shall be prepared in accordance with the following requirements:

1. The Bid form furnished by the DISTRICT shall be used and shall not be altered.
2. Entries shall be typed or written in ink; signatures shall be written in ink.
3. The Bidder shall submit a unit or lump sum price for every item in the Bid form unless specific directions in the Invitation for Bids allow for partial Bids. The unit or lump sum bid prices for the various Contract Items shall be typed or written figures in ink, and shall be clearly legible.
4. A Total Bid shall be entered in the Bid form for every item on which a unit price has been submitted. The Total Bid for each item other than lump sum items shall be determined by multiplying each unit price bid by the quantity for that item, and shall be written in figures in the "Total Bid" column in the Bid form. In case of a discrepancy between the unit price bid for a Contract Item and the Total Bid for that item, the unit price bid shall govern. In the case of lump sum items, the price shall be written in figures in the "Total Bid" column in the Bid form.
5. The Total Contract Bid Price shall be written in figures in the proper place in the Bid form. The Total Contract Bid Price shall be determined by adding the Total Bid for each item.
6. Changes in any entry shall be made by marking through the entry in ink and making the correct entry adjacent thereto in ink. The individual signing the Bid shall initial the change in ink.
7. The Bid shall be properly executed. In order to constitute proper execution, the Bid shall be executed in strict compliance with the following. No other forms of execution will be accepted.
 - a. If a Bid is by an individual, it shall show the name and address of the individual and shall be signed by the individual.
 - b. If the Bid is by a Corporation, it shall be executed in the name of the Corporation by the President or Vice-president. It shall be attested by the Secretary or Assistant Secretary. The seal of the Corporation shall be affixed. The Bid shall show the address of the principal office of the Corporation.
 - c. If the Bid is made by a Partnership, it shall be executed in the name of the Partnership by one of the general partners. The address of the Partnership shall also be shown.
 - d. If the Bid is a joint venture, it shall be executed by each of the joint venturers with an address for each joint venturer and the address for the joint venture itself.
8. The Bid shall not contain any unauthorized additions, deletions or conditional bids.
9. The Bidder shall not add any provisions reserving the right to accept or reject an award, or to enter into a Contract pursuant to an award.
10. The Bid shall not contain irregularities of any kind which, in the opinion of the DISTRICT, make the Bid incomplete, indefinite, or ambiguous as to its meaning.
11. Alternative Bids will not be considered unless specifically called for. Where numbered

Section III - Instructions To Bidders

Alternate Bid Items are provided under any Contract, each Bidder must submit a bid price for each numbered Alternate Item.

12. All attachments, certifications or acknowledgements attached to the Bid shall be executed in the same manner as the Bid.

ARTICLE II FILING OF PROPOSALS:

Each Bid shall be made on the forms incorporated in these documents. Clear and legible duplicate copies of the blank bid document forms provided may be used for entry. One (1) copy of each of these bid document forms are to be used to prepare the Contractor's bid proposal. It is not necessary to submit the entire specifications documents on the bid date, only the forms specified below. The Contractor (bidder) is cautioned that all spaces on the Proposal must be fully completed, including all identified or voluntary alternates, if any, and that the Proposal must be properly signed with the name of the company, its authorized representatives, and shall be fully executed in all respects. If this is a Formal Contract, the Bid Security documents shall be fully executed and signed/sealed by the Bidder and the Security Company and shall be witnessed and notarized as required by NC Statutes. This includes the Power of Attorney, attached and properly executed by the Security Company. All documents submitted with the bid shall be original documents and clearly show the original signatures and seals.

Formal Bid Contracts (Bid Bond required):

Bids shall be submitted in a two (2) envelope system. The outer envelope shall bear the project name and project number, and shall be sealed and addressed to the Metropolitan Sewerage District of Buncombe County, North Carolina, 2028 Riverside Drive, Asheville, North Carolina 28804. The **name, address, and license number of the bidder**, as well as the type of contract, if applicable, shall also be shown on the outside (Single-Prime-General, or Separate-Prime-General, Plumbing, HVAC or Electrical). The outer envelope shall contain the following documents, fully executed and signed/sealed as required in these Instructions to Bidders:

1. Proposal Guaranty (Bid Security) and Power of Attorney
2. Certification of receipt of Addenda written on Contractor's letterhead
3. Non-Collusion Affidavit
4. A sealed smaller envelope containing the proposal and Schedule of Estimated Quantities and Bid Prices and marked on the outside "PROPOSAL". This envelope should also contain the project name and the name, address, and license number of the bidder. **Attached to the proposal shall be the appropriate MBE form(s).**

Informal Bid Contracts (Bid Bond not required):

Bids shall be submitted in a one (1) envelope system. The envelope shall bear the project name and project number, and shall be sealed and addressed to the Metropolitan Sewerage District of Buncombe County, North Carolina, 2028 Riverside Drive, Asheville, North Carolina 28804. The **name, address, and license number of the bidder**, as well as the type of contract, if applicable, shall also be shown on the outside (Single-Prime-General, or Separate-Prime-General, Plumbing, HVAC or Electrical). The envelope shall contain the following documents, fully executed and signed/sealed as required in these Instructions to Bidders:

Section III - Instructions To Bidders

1. Proposal Form with attached Schedule of Estimated Quantities and Bid Prices
2. Certification of receipt of Addenda written on Contractor's letterhead
3. Non-Collusion Affidavit
4. Appropriate MBE form(s)

ARTICLE III OPENING OF PROPOSALS:

Bids received prior to the advertised hour of opening will be securely kept, sealed. The officer whose duty it is to open them will decide when the specified time has arrived, and no Bid received thereafter will be considered; except that when a Bid arrives by mail after the time fixed for opening, but before the reading of all other Bids is completed, and it is shown to the satisfaction of the DISTRICT that the non-arrival on time was due solely to delay in the mail for which the bidder was not responsible, such Bid will be received and considered. Mailed Bids will be treated in every respect as though filed in person and will be subject to the same requirements. Bids received subsequent to the advertised hour of opening will be returned to the Bidder unopened.

The Bid opening will be open to all interested parties.

Bid tabulation forms will be prepared by the ENGINEER and will be provided to all interested parties attending the bid opening. Forms will contain the names of prospective bidders and blank spaces for recording the bidder's license number, bid security, base bid and alternates, if any. Spaces for unit prices will not be provided.

Approximately five (5) minutes prior to the designated time for receiving bids the ENGINEER or his representative will announce the "official time" that will be used in declaring the bidding closed.

At the time fixed for the opening of Bids, the ENGINEER will declare the bidding closed. After which, the ENGINEER will determine if at least three (3) bids (sealed envelopes) have been received for the contract. Should there not be at least three, the bids will not be opened. The bids will be returned to the bidders and they will be requested to submit a bid proposal with a re-advertisement.

Since this is a public bid opening, all bids will then be opened and read aloud to the assembled group, beginning with the General Contract bids. The following order will be observed for Formal Bid Contracts:

1. The outer envelopes of all bidders will be opened prior to reading any "Proposals". Prior to opening an outer envelope, the name of the bidder and license number as it appears on the envelope will be announced to the assembled group.
2. With the opening of the bidder's outer envelope, a preliminary determination will be made that bid security and other required certifications are enclosed with the bid.
3. If all of the required material is not with at least three (3) of the bids for a particular contract, the sealed envelopes marked "Proposal" will not be opened.
4. If it is determined that at least three (3) of the outer envelopes appear to be in order, the sealed envelopes containing the bid proposals shall be opened and the bids read aloud.

Section III - Instructions To Bidders

After such determination, all remaining bids may be opened and read aloud without first making a preliminary determination as to the adequacy of bid security.

If this is an informal bid contract, the envelope will be opened and a determination will be made that all the required documents are enclosed and properly executed.

ARTICLE IV WITHDRAWAL OR REVISION OF BIDS:

A Bidder may, without prejudice to himself, withdraw a Bid after it has been delivered to the DISTRICT provided such withdrawal is made in accordance with N.C. General Statute Section 143-129.1.

Only those persons authorized to sign Bids shall be recognized as being qualified to withdraw a Bid.

ARTICLE V ADDENDA AND INTERPRETATIONS:

No interpretations of the meaning of the Plans, Specifications or other portions of the Contract Documents will be made orally.

Every request for interpretation of Plans, Specifications or any portion of the Contract Documents shall be in writing and must be addressed to the office of the DISTRICT, and to be given consideration must be received by the DISTRICT at least five (5) days prior to the date fixed for the opening of Bids. DISTRICT shall determine, in its sole discretion, whether or not a request for clarification or interpretation requires a formal Addendum. Written Addenda, if issued, will be sent by certified or registered mail with return receipt requested, or facsimile with confirmation, or by e-mailed PDF with confirmation, to all holders of Contract Documents at the respective addresses, facsimile numbers, or e-mail addresses furnished for such purposes not later than three (3) days prior to the day fixed for the opening of bids.

Failure of any Bidder to receive any such Addenda shall not relieve said Bidder from any obligation under his Bid as submitted. All Addenda so issued shall become part of the Contract Documents.

Prospective Bidders are cautioned concerning the use of a Post Office Box address as telegraphic Addenda cannot be sent to Post Office Boxes.

ARTICLE VI DISCREPANCY IN BIDS:

In the event there is a discrepancy in any Bid between the unit prices and the extended totals, the unit prices shall govern. Bids which do not contain a price for every numbered item contained in the applicable Bid form will not be accepted, unless otherwise specified.

ARTICLE VII QUALIFICATIONS OF BIDDERS:

The DISTRICT may make such investigation as he deems necessary to determine the qualifications of the Bidder to perform the work and the Bidder shall furnish to the DISTRICT all such information and data for this purpose as the DISTRICT may request. The DISTRICT reserves the right to reject any and all Bids if the evidence submitted by, or investigation of, such Bidder fails to satisfy the DISTRICT that such Bidder is properly qualified to carry out the obligations of the Contract, and to complete the work contemplated therein. Conditional bids will not be accepted.

Section III - Instructions To Bidders

The Bidder shall submit, with his Bid, a list of Subcontractors, Suppliers, etc., indicating projects recently completed of a similar nature along with names, addresses and phone numbers of their clients for reference of qualifications.

Bidders shall comply with all applicable laws regulating the practice of General Contracting as contained in Chapter 87 of the General Statutes of North Carolina.

All Bidders must be Utility or Unclassified Contractors licensed in the State of North Carolina to perform work of a nature as required by the Contract Documents.

ARTICLE VIII BID SECURITY:

For Formal Bid Contracts, each bid must be accompanied by a Bid Bond, cash, cashiers check or a certified check of the Bidder made payable to the DISTRICT in an amount not less than five percent (5%) of the amount of the Bid. Bid Bonds shall be issued by a corporate surety licensed under the laws of North Carolina to execute such bonds.

When the Bidder elects to submit a certified check or cashiers check as his Bid Bond, the check shall be drawn on a bank or trust company insured by the Federal Deposit Insurance Corporation.

Where alternate items are included in the Bid, the amount of bid security shall be not less than five percent (5%) of the base bid and all alternates combined.

Please note that while not required, it is helpful to use the Bid Bond form already provided in these contract documents. All language contained within this bond form is acceptable to the District. Non-MSD forms may contain unacceptable language and cause your bid to be rejected. Please also note that the use of "AIA" type bid bonds is not acceptable and will cause your bid to be rejected.

The security of the Bidders will be released upon the earlier to occur of (a) the expiration of five days after the Contract has been signed by the accepted Bidder and the DISTRICT; or (b) the expiration of sixty (60) days after the day the bids are opened, upon demand of any such bidders whose bid has not been accepted prior to such demand.

In the event that all Bids are rejected, the security of all Bidders whose security has not been previously returned will be returned at the time of such rejection.

ARTICLE IX RESPONSIBILITIES OF BIDDERS:

Each bidder shall, by careful examination, satisfy himself as to the nature and location of the work, the conformation of the ground, the character, quality and quantity of the facilities needed preliminary to and during the prosecution of the work, the general and local conditions, and all other matters which can in any way affect the work or the cost thereof under the Contract.

The Bidder shall make his own determination as to the nature and extent of the utility facilities, including proposed adjustments, new facilities, or temporary work to be performed by the utility owner or his representative; and as to whether or not any utility work is planned by the DISTRICT in conjunction with the project construction. The Bidder shall consider in his Bid all the permanent and temporary utility facilities in their present or relocation positions, whether or not specifically shown on the Plans or covered in the project Special Conditions. It will be the Bidder's responsibility to anticipate any

Section III - Instructions To Bidders

additional costs to him resulting from such utility work and to reflect these costs in his Bid for the various items in the Contract.

The failure or omission of any Bidder to thoroughly examine and familiarize himself with the Contract Documents or to receive or examine any form, instrument or document or visit the site and acquaint himself with the conditions there existing shall in no way relieve any Bidder from any obligation in respect to his bid.

No verbal agreement or conversation with any officer, agent or employee of the DISTRICT, either before or after the execution of the Contract, shall affect or modify any of the terms or obligations therein.

ARTICLE X COLLUSIVE AGREEMENTS:

Each Bidder submitting a Bid to the DISTRICT for any portion of the work contemplated by the documents on which bidding is based, shall execute and attach thereto an affidavit substantially in the form herein provided, to the effect that he has not entered into a collusive agreement with any person, firm or corporation in regard to any Bid submitted.

Before executing any Sub-contract, the successful Bidder shall submit the name of any proposed Sub-contractor for prior approval and an affidavit substantially as above.

ARTICLE XI TAXES

The Bidder shall include in his Bid the cost of all sales and use taxes and furnish to the DISTRICT at the end of each month and upon completion of his Contract, a statement setting forth all such taxes paid. This statement shall indicate the amount paid to each firm and be adequate for audit by the State Department of Revenue and must be accompanied by copies of invoices.

ARTICLE XII COMPARISON OF BIDS:

Bids will be compared on the basis of the totals of the approximated quantities comprising all items, at the unit and lump sum prices bid for these items. The resulting total Contract Bid Price will be compared which will include and cover the furnishing of all materials, and the performance of all labor necessary, and completing of all the work called for under the accompanying Contract, and in the manner set forth and described in the Contract Documents.

The lowest Bidder under each Contract will be that Bidder whose Bid totals the lowest number of dollars as determined above.

When numbered Alternate bid items are required, the lowest Bidder is the Bidder whose Base Bid and Bid for the Alternate or combination of Alternates selected by the DISTRICT results in the lowest total amount. The DISTRICT reserves the right to select any Alternate or combinations of Alternates.

Where estimated quantities are included in certain items of the Bid, they are for the purpose of comparing bids. While they are believed to be close approximations, they are not guaranteed, and settlement will be made from such items upon the basis of work as actually executed at the unit prices in the Bid as accepted.

Section III - Instructions To Bidders

ARTICLE XIII AWARD OF CONTRACT:

The contract shall be awarded to the lowest responsive, responsible bidder, taking into consideration quality, performance and time of delivery. The DISTRICT reserves the right to reject any and all bids, including, without limitation, the right to reject any or all non-conforming, non-responsive, unbalanced or conditional bids, and to reject the bid of any bidder if the DISTRICT believes that it would not be in the best interest of the DISTRICT to make an award to that bidder. The DISTRICT also reserves the right to waive informalities.

When Alternate Bid items are required in the Bid, the Contract will be awarded to that responsible Bidder whose Base Bid and Bid for the Alternate or combination of Alternates selected by the DISTRICT results in the lowest total amount.

These Bids are asked for in good faith, and awards will be made as soon as practicable, provided satisfactory Bids are received.

The DISTRICT may reject any bid not prepared and submitted in accordance with the provisions of the bid documents.

The right is reserved to waive informalities in bidding, to reject any or all Bids, or to accept a Bid other than the lowest submitted if such action is deemed to be in the best interest of the DISTRICT.

ARTICLE XIV COMMENCEMENT OF WORK:

Upon execution and delivery of the Contract and the delivery of the required performance and payment bonds and insurance certificates and policies, the CONTRACTOR will be notified to proceed with the Work of the Contract. The work of the Contract shall be commenced within ten (10) days following such notification or as otherwise specified in the Notice to Proceed.

The CONTRACTOR shall notify the DISTRICT in writing, of his intention to enter upon the site of the work at least five (5) days in advance of such entrance.

ARTICLE XV DAMAGES FOR FAILURE TO EXECUTE CONTRACT:

If an accepted Bidder shall fail or refuse to sign and deliver this Contract and the required surety bonds and insurance documentation within ten (10) days after he has received Notice of Award of his Bid, the DISTRICT shall retain, as partial damages for such failure or refusal, the Bid security of such defaulting Bidder. In addition to such damages, the DISTRICT reserves the right to pursue any other remedies it may have against such defaulting Bidder.

ARTICLE XVI EQUAL EMPLOYMENT OPPORTUNITY

Attention of Bidders is particularly called to the requirements for insuring that employees and applicants for employment are not discriminated against because of their race, color, religion, sex, or national origin.

ARTICLE XVII WAGES AND SALARIES

The Bidder and his Subcontractors shall be required to pay all employees the minimum prevailing wage and salary rates for the full length of the contract.

TABLE OF CONTENTS

Article Number	Title	Page
0	Index to General Conditions	2
1	Definitions	6
2	Preliminary Matters	9
3	Contract Documents: Intent, Amending and Reuse	11
4	Availability of Lands: Physical Conditions; Reference Points	12
5	Bonds and Insurance	14
6	Contractor's Responsibilities	20
7	Other Work	27
8	District's Responsibilities	28
9	Engineer's Status During Construction	28
10	Changes in The Work	31
11	Change of Contract Price	32
12	Change of Contract Time	36
13	Warranty and Guarantee; Tests and Inspections; Correction, Removal or Acceptance of Defective Work	36
14	Payments to Contractor and Completion	39
15	Suspension of Work and Termination	44
16	Conflict/Appeals Resolution	46
17	Miscellaneous	46

INDEX TO GENERAL CONDITIONS

Acceptance of Insurance.....	5.14	Contractor-definition of.....	1
Access to the Work.....	13.2	Contractor May Stop Work Or Terminate.....	15.5
Addenda-definition of (see definition of Specifications).....	1	Contractor's Cont. Obligation.....	14.16
Agreement-definition of.....	1	Contractor's Duty to Report Discrepancy in Documents.....	2.6, 3.3
All Risk Insurance.....	5.12	Contractor' Fee-Cost Plus	11.4.5.6, 11.5
Amendment-definition of, Written.....	1, 3.4	Contractor's Liability Insurance.....	5.8
Appeals Resolution.....	16	Contractor's Responsibilities- In General.....	6
Application for Payment- definition of.....	1	Contractor's Warranty of Title.....	14.3
Application for Payment-Final.....	14.12	Contractor's-other work.....	7
Application for Progress Payment.....	14.2	Contractual Liability Insurance.....	5.9
Application for Progress Payment- review of.....	14.4-14.8	Coordinating Contractor - Definition of.....	7.4
Authorized Variation in Work.....	9.5	Coordination.....	7.4
Availability of Lands.....	4.1	Copies of Documents.....	2.2, 2.3
Award, Notice of-defined.....	1	Correction or Removal of Defective Work.....	13.11
Before Starting Construction.....	2.6-2.8	Correction Period, One Year.....	13.12
Bid-definition of.....	1	Correction, Removal or Acceptance of Defective Work-In Gen.....	13.11-13.14
Bonds and Insurance-in general.....	5	Cost-net decrease.....	11.5.2.4
Bonds, Delivery of.....	2.1, 5.1	Cost of Work.....	11.4
Bonds, Performance and Other.....	5.1-5.2	Costs, Supplemental.....	11.4.5
Cash Allowances.....	11.7	Day-definition of.....	1
Change Order-definition of.....	1	Defective-definition of.....	1
Change Orders-to be executed.....	10.4	Defective Work, Acceptance of.....	13.13
Changes in the Work.....	10	Correction or Removal of.....	13.11
Claims, Waiver of- on Final Payment.....	14.17	In General.....	13, 14.7, 14.12
Clarifications and Interpretations.....	9.4	Rejecting.....	9.6
Cleaning.....	6.17	Definitions.....	1
Completion.....	14	Delivery of Bonds.....	2.1
Completion, Substantial.....	14.9, 14.10	Determination for Unit Prices.....	9.10
Conference, Preconstruction.....	2.9	Disputes, Decisions by Engineer.....	9.11-9.12
Conflict, Error, Discrepancy- Contractor to Report.....	2.6, 3.3	Documents, Copies of.....	2.2, 2.3
Construction Machinery, Equipment, etc.....	6.4	Documents, Record.....	6.19
Continuing Work.....	6.29	Documents, Reuse.....	3.6
Contract Documents- Amending and Supplementing.....	3.4-3.5	Drawings, definition of.....	1
Contract Documents-definition of.....	1	Easements.....	4.1
Contract Documents-Intent.....	3.1-3.3	Effective date of Agreement - definition of.....	1
Contract Documents-Reuse of.....	3.6	Emergencies.....	6.22
Contract Price, Change of.....	11	Engineer-definition of.....	1
Contract Price-Definition.....	1	Engineer's Decisions.....	9.10-9.12
Contract Time, Change of.....	12	Engineer's-Notice Work is	
Contract Time, Commencement of.....	2.4		
Contract Time-definition of.....	1		

Section IV - General Conditions

Acceptable.....14.14
 Engineer's Recommendation
 of Payment.....14.4, 14.12
 Engineer's Responsibilities,
 Limitations on.....6.6, 9.11, 9.13-9.16
 Engineer's Status During Construction -
 In General.....9
 Equipment, Labor, Materials and.....6.3, 6.5
 Equivalent Materials and Equipment.....6.7
 Explorations of Physical Conditions.....4.2

 Fee, Contractor's-Cost Plus.....11.5
 Field Order-definition of.....1
 Field Order -
 Issued by Engineer.....3.5.1, 9.5
 Final Application for Payment.....14.13
 Final Inspection.....14.12
 Final Payment and Acceptance.....14.14
 Final Payment -
 Recommendation of.....14.14, 14.15

 General Provisions.....17.3-17.4
 General Requirements -
 Definition of.....1
 General Requirements -
 Principal references to..... 4.4, 6.4,
 6.6-6.7, 6.23
 Giving Notice.....17.1
 Guarantee of Work-by Contractor.....13.1

 Indemnification.....6.30-6.32
 Inspection, Final.....14.12
 Inspection, Tests and.....13.3
 Insurance, Bonds and-in general.....5
 Insurance, Certificates of.....2.8, 5
 Insurance-Completed operations.....5.8
 Insurance, Contractor's Liability.....5.8
 Insurance, Contractual Liability.....5.9
 Insurance, District's Liability.....5.11
 Insurance, Property.....5.12-5.16
 Insurance, Waiver of Rights.....5.17
 Intent of Contract Documents3.3, 9.14
 Interpretations and Clarifications.....9.4
 Investigations of
 physical conditions.....4.2
 Labor, Materials & Equipment.....6.3-
 6.5
 Laws and Regulations-definition
 of.....1
 Laws and Regulations-
 general.....6.14
 Liability Insurance-

Contractor's.....5.8
 Liability Insurance-
 District's.....5.11
 Liens-definitions of.....14.2
 Limitations on Engineers Respon -
 sibilities6.6, 9.11, 9.13-9.16

 Materials and equipment -
 furnished by Contractor.....6.3
 Materials and equipment -
 not incorporated in Work.....14.2
 Materials or equipment-
 equivalent.....6.7
 Miscellaneous
 Provisions.....17
 Multi-prime
 contracts.....7

 Notice, Giving of.....17.1
 Notice of Acceptability
 of Project.....14.14
 Notice of Award-definition
 of.....1
 Notice to Proceed-definition
 of.....1
 Notice to Proceed-giving of.....2.4

 "Or-Equal" Items.....6.7
 Other Contractors.....7
 Other Work.....7
 Overtime Work-prohibition of.....6.3
 District-definition of1
 District May Correct Defective
 Work.....13.14
 District May Stop Work.....13.10
 District May Suspend Work,
 Terminate.....15.1-15.4
 District's Duty to Execute
 Change Orders.....11.7
 District's Liability Insurance.....5.11
 District's Representative-Engineer
 to serve as.....9.1
 District's Responsibilities -
 in general.....8
 District's Separate Representative
 at site.....9.3

 Partial Utilization.....14.11
 Partial Utilization -
 definition of.....1
 Partial Utilization -
 Property Insurance.....5.21

Section IV - General Conditions

Patent Fees and	provision for.....9.3
Royalties.....6.12	Responsibilities, Contractor's -
Payments, Recommendation of.....14.4-14.7, 14.14	in general.....6
Payments to Contractor-in general.....14	Responsibilities, Engineer's -
When due.....14.4, 14.14	in general.....9
Withholding.....14.7	Responsibilities, District's -
Performance and other Bonds.....5.1-5.2	in general.....8
Permits.....6.13	Retainage.....14.2
Physical Conditions.....4.2	Reuse of Documents.....3.6
Engineer's Review of.....4.2.4	Rights of Way.....4.1
Existing Structures.....4.2.2	Royalties, Patent Fees and.....6.12
Explorations and Reports.....4.2.1	
Possible Document Change.....4.2.5	Safety and Protection.....6.20-6.21
Price and Time Adjustment.....4.2.6	Samples.....6.23-6.28
Report of Differing.....4.2.3	Schedule of progress -
Underground Utilities.....4.3	2.7-2.11, 6.6, 6.29, 15.2.6
Preconstruction Conference.....2.9	Schedule of Shop Drawing
Preliminary Matters.....2	Submissions..... 2.7-2.9, 6.23
Premises, Use of.....6.16-6.18	Schedule of values.....2.11, 14.1
Price, Change of Contract.....11	Schedules, Finalizing.....2.11
Price-Contract-definition of.....1	Shop Drawings and Samples.....6.23-6.28
Progress Payment, Applications for.....14.2	Shop Drawings-definition of.....1
Progress Payment-Retainage.....14.2	Shop Drawings, use to approve
Progress schedule.....2.7, 2.9, 6.6, 6.29, 15.2.6	substitutions.....6.7.3
Project-definition of.....1	Site, Visits to-by Engineer.....9.2
Project Representation -	Special Conditions.....4.2, 7.4
provision for.....9.3	Specifications-definition of.....1
Project Representative, Resident -	Starting Construction -
definition of.....1	Before.....2.6-2.8
Project, Starting the.....2.5	Starting the Project.....2.5
Property Insurance.....5.7, 5.12	Stopping Work-by Contractor.....15.5
Partial Utilization of.....5.21	Stopping Work-by District.....13.10
Receipt and Application	Subcontractor-definition of.....1
of Proceeds.....5.18-5.19	Subcontractors-in general.....6.8-6.11
Protection, Safety and.....6.20-6.21	Subcontracts required
Punch List.....14.12	provisions.....5.17.1, 6.11, 11.4.3
	Substantial Completion -
Recommendation of Payment.....14.4, 14.14	certification of.....14.9
Record Documents.....6.19	definition of.....1
Reference Points.....4.4	Substitute or "Or-Equal" Items.....6.7
Regular working hours.....1, 6.3	Subsurface Conditions.....4.2, 4.3
Regulations, Laws and.....6.14	Supplemental costs.....11.4.5
Rejecting Defective Work.....9.6	Supplementing Contract
Related Work at Site.....7.1-7.3	Documents.....3.4, 3.5
Remedies Not Exclusive.....17.4	Supplier-definition of.....1
Removal or Correction	Supplier-principal
of Defective Work.....13.11	references to.....3.6, 6.5, 6.7-6.11,
Resident Project Representative -	6.20 6.24, 9.13, 9.16, 11.7, 13.4, 14.13
definition of.....1	Surety-consent to payment.....14.13, 14.15
	Surety-Engineer has no duty to.....9.13
	Surety-notice to.....10.1, 10.5, 15.2
	Surety-qualification of.....5.1-5.2

Section IV - General Conditions

Suspending Work, by District.....	15.1	Values, Schedule of.....	2.11, 14.1
Suspension of Work and Termination -		Variations in Work -	
in general.....	15	Authorized.....	6.25, 6.27, 9.5
Superintendent-Contractor's.....	6.2	Visits to Site-by Engineer.....	9.2
Supervision and			
Superintendence.....	6.1, 6.2		
		Waiver of Claims -	
Taxes-Payment by Contractor.....	6.15	on Final Payment.....	14.17
Termination-by Contractor.....	15.5	Waiver of Rights	
Termination-by District.....	15.2-15.4	by insured parties.....	5.6, 6.11
Termination, Suspension of Work -		Warranty and Guarantee -	
in general.....	15	by Contractor.....	13.1
Tests and Inspections.....	13.3-13.7	Warranty of Title, Contractor's.....	14.3
Time, Change of Contract.....	12	Work, access to.....	13.2
Time, Computation of.....	17.2	Work-by others.....	7
Time, Contract-definition of.....	1	Work Continuing During Disputes.....	6.29
		Work, Costs of.....	11.4
Uncovering Work.....	13.8, 13.9	Work-definition of.....	1
Underground Facilities -		Work Directive Change -	
definition of.....	1	definition of.....	1
not shown or indicated.....	4.3.2	principal references to.....	3.4.3, 10.1-10.2
protection of.....	4.3, 6.20	Work, Neglected by Contractor.....	13.14
shown or indicated.....	4.3.1	Work, Stopping by Contractor.....	15.5
Unit Price Work-definition of.....	1	Work, Stopping by District.....	15.1-15.4
general.....	11.8, 14.1, 14.5	Written Amendment-definition of.....	1
Unit Prices.....	11.3.1	Written Amendment -	
Unit Prices, Determinations for.....	9.10	principal references to.....	3.4.1, 10.1,
Use of Premises.....	6.16-6.18		11.2, 12.1
Utility Owners.....	6.13, 6.20, 7.2, 7.3		

Section IV - General Conditions

ARTICLE 1--DEFINITIONS

Wherever used in these General Conditions or in the other Contract Documents the following terms have the meanings indicated which are applicable to both the singular and plural thereof:

Addenda - Written or graphic instruments issued prior to the opening of Bids which clarify, correct or change the bidding documents or the Contract Documents.

Agreement - The written agreement between DISTRICT and CONTRACTOR covering the Work to be performed; other Contract Documents are attached to the Agreement and made a part thereof as provided therein.

Application for Payment - The form accepted by ENGINEER which is to be used by CONTRACTOR in requesting progress or final payments and which is to include such supporting documentation as is required by the Contract Documents.

Bid - The offer or proposal of the bidder submitted on the prescribed form setting forth the prices for the Work to be performed.

Bonds - Bid, performance and payment bonds and other instruments of security.

Change Order - A document recommended by ENGINEER, which is signed by CONTRACTOR and DISTRICT and authorizes an addition, deletion or revision in the Work, or an adjustment in the Contract Price or the Contract Time, issued on or after the Effective Date of the Agreement.

Contract Documents - The Agreement, Addenda (which pertain to the Contract Documents), CONTRACTOR's Bid (including documentation accompanying the Bid and any post-Bid documentation submitted prior to the Notice of Award), Bonds, these General Conditions, the Special Conditions, the Specifications and the Plans as the same are more specifically identified in the Agreement, together with all amendments, modifications and supplements issued pursuant to paragraphs 3.4 and 3.5 on or after the Effective Date of the Agreement.

Contract Price - the monies payable by DISTRICT to CONTRACTOR under the Contract Documents as stated in the Agreement (subject to the provisions of paragraph 11.8.1 in the case of Unit Price Work).

Contract Time - The number of days (computed as provided in paragraph 17.2) or the date stated in the Agreement for the completion of the Work.

Contractor - The person, firm or corporation with whom the DISTRICT has entered into the Agreement.

Day - Consecutive 24 hour period including Saturday or Sunday.

Defective - An adjective which when modifying the word Work refers to Work that is unsatisfactory, faulty or deficient, or does not conform to the Contract Documents, or does not meet the requirements of any inspection, reference standard, test or approval referred to in the Contract Documents, or has been damaged prior to ENGINEER's recommendation of final payment (unless responsibility for the protection thereof has been assumed by DISTRICT at Substantial Completion in accordance with paragraph 14.8 or 14.10).

District - The Metropolitan Sewerage District of Buncombe County, N.C., with whom the CONTRACTOR has entered into the Agreement and for whom the Work is to be provided.

Section IV - General Conditions

Effective Date of the Agreement - The date indicated in the Agreement on which it becomes effective, but if not, it means that date on which the Agreement is signed and delivered by the last of the two parties to sign and deliver.

Engineer - The DISTRICT's representative who is in responsible charge of the Work.

Field Order - A written order issued by ENGINEER which orders minor changes in the Work in accordance with paragraph 9.5; but which does not involve a change in the Contract Price or the Contract Time.

General Requirements - As stated in the Specifications and Requirements of the Agreement.

Inspector - The authorized representative of the ENGINEER assigned to make a detailed inspection of any or all portions of the work and materials.

Laws and Regulations; Laws or Regulations - Statutes of the U.S. Government, the State of North Carolina or other rules, regulations, ordinances or codes adopted by governmental authorities having appropriate jurisdiction.

Notice of Award -The written notice by DISTRICT to the apparent successful bidder stating that upon compliance by the apparent successful bidder with the conditions precedent enumerated therein, within the time specified, DISTRICT will sign and deliver the Agreement.

Notice to Proceed - A written notice given by DISTRICT to CONTRACTOR (with a copy to ENGINEER) fixing the date on which the Contract Time will commence to run and on which CONTRACTOR shall start to perform CONTRACTOR's obligations under the Contract Documents.

Partial Utilization - Placing a portion of the Work in service for the purpose for which it is intended (or a related purpose) before reaching Substantial Completion for all the Work.

Plans - The drawings which show the character and scope of the Work to be performed and which have been prepared or approved by ENGINEER and are referred to in the Contract Documents.

Project - The total construction of which the Work to be provided under the Contract Documents may be the whole, or a part as indicated elsewhere in the Contract Documents.

Regular Working Hours - Monday through Friday from 8:00 a.m. to 5:00 p.m.

Retainage - The amount of money retained by the DISTRICT until such time as the Work is complete and approved by the DISTRICT.

Shop Drawings - All drawings, diagrams, illustrations, schedules and other data which are specifically prepared by or for CONTRACTOR to illustrate some portion of the Work and all illustrations, brochures, standard schedules, performance charts, instructions, diagrams and other information prepared by a Supplier and submitted by CONTRACTOR to illustrate material or equipment for some portion of the Work.

Special Conditions - Part of the Contract Documents which amends or supplements the General Conditions and applies to the Work.

Section IV - General Conditions

Specifications - Those portions of the Contract Documents consisting of written technical descriptions of materials, equipment, construction systems, standards and workmanship as applied to the Work and certain administrative details applicable thereto.

Subcontractor - An individual, firm or corporation having a direct contract with CONTRACTOR or with any other subcontractor for the performance of a part of the Work at the site.

Substantial Completion - The Work (or a specified part thereof) has progressed to the point where, in the opinion of ENGINEER as evidenced by ENGINEER's definitive certificate of Substantial Completion, it is sufficiently complete, in accordance with the Contract Documents, so that the Work (or specified part) can be utilized for the purposes for which it is intended; or if there be no such certificate issued, when final payment is due in accordance with paragraph 14.13. The terms "substantially complete" and "substantially completed" as applied to any Work refer to Substantial Completion thereof.

Supplier - A manufacturer, fabricator, supplier, distributor, materialman or vendor.

Unbalanced Bid - A bid which includes any unbalanced bid price.

Underground Facilities - All pipelines, conduits, ducts, cables, wires, manholes, vaults, tanks, tunnels or other such facilities or attachments, and any encasements containing such facilities which have been installed underground to furnish any of the following services or materials; electricity, gases, steam, liquid petroleum products, telephone or other communications, cable television, sewage and drainage removal, traffic or other control systems or water.

Unit Price Work - Work to be paid for on the basis of unit prices.

Work - The entire completed construction or the various separately identifiable parts thereof required to be furnished under the Contract Documents. Work includes performing services, furnishing labor and material and incorporating materials and equipment into the construction, all as required by the Contract Documents.

Work Directive Change - A written directive to CONTRACTOR, issued on or after the Effective Date of the Agreement and signed by the ENGINEER, ordering an addition, deletion or revision in the Work, or responding to differing or unforeseen physical conditions under which the work is to be performed as provided in paragraph 4.2 or 4.3 or to emergencies under paragraph 6.22. A Work Directive Change may not change the Contract Price or the Contract Time, but is evidence that the parties expect that the change directed or documented by a Work Directive change will be incorporated in a subsequently issued Change Order following negotiations by the parties as to its effect, if any, on the Contract Price or Contract Time as provided in paragraph 10.2.

Written Amendment - A written amendment of the Contract Documents, signed by DISTRICT and CONTRACTOR on or after the Effective Date of the Agreement.

ARTICLE 2 --PRELIMINARY MATTERS

Delivery of Bonds:

2.1 When CONTRACTOR delivers the executed Agreements to DISTRICT, CONTRACTOR shall also

Rev 6 10

Section IV - General Conditions

deliver to DISTRICT such Bonds as CONTRACTOR may be required to furnish in accordance with paragraph 5.1.

Copies of Documents:

2.2 The CONTRACTOR shall be required to post all bonds, acquire any insurance, and offer any warranties required in obtaining the permits demanded by the Work. The CONTRACTOR shall be responsible for all notifications and acceptances required by those permits.

2.3 DISTRICT shall furnish to CONTRACTOR up to five copies of the Contract Documents as are reasonably necessary for the execution of the Work. Additional copies will be furnished, upon request, at the cost of reproduction.

Commencement of Contract Time; Notice to Proceed:

2.4 The Contract Time will commence to run on the tenth day after the Effective Date of the Agreement, or, if a Notice to Proceed is given, on the day indicated in the Notice to Proceed. A Notice to Proceed may be given at any time within ten days after the Effective Date of the Agreement.

Starting the Project:

2.5 CONTRACTOR shall start to perform the Work on the date when the Contract Time commences to run, but no Work shall be done at the site prior to the date on which the Contract Time commences to run.

Before Starting Construction:

2.6 Before undertaking each part of the Work, CONTRACTOR shall carefully study and compare the Contract Documents and check and verify pertinent figures shown thereon and all applicable field measurements. CONTRACTOR shall promptly report in writing to ENGINEER any conflict, error or discrepancy which CONTRACTOR may discover and shall obtain a written interpretation or clarification from ENGINEER before proceeding with any Work affected thereby; however, CONTRACTOR shall not be liable to DISTRICT or ENGINEER for failure to report any conflict, error or discrepancy in the Contract Documents, unless CONTRACTOR had actual knowledge thereof or should reasonably have been aware of such discrepancy.

2.7 CONTRACTOR shall, within thirty (30) days after receipt of Notice of Award, prepare and submit to the DISTRICT for approval a practicable construction schedule showing the order in which the CONTRACTOR proposes to carry out the work, the date on which he will start the prominent features and the contemplated dates for completing such prominent features. The schedule may be in any form, at the option of the CONTRACTOR, but shall maintain current with each submittal for progress payment, with at least the following information:

2.7.1 The various classes and area of work broken down into times projected for submittals, approvals and procurement; times for installation and erection; and times for testing and inspection.

2.7.2 Line by line breakdown.

2.7.3 The work completed and the work remaining to complete the project.

2.7.4 Any items of work which will delay the start or completion of other major items of work so as to delay completion of the whole project.

Section IV - General Conditions

2.7.5 Material suppliers and subcontractors listings – as soon as possible, but in no case more than thirty (30) days after receipt of the Notice of Award, the CONTRACTOR shall supply the names and addresses of all major material suppliers and subcontractors to the DISTRICT.

2.7.6 Shop Drawings and Samples – CONTRACTOR shall submit shop drawings and samples accompanied by his standard transmittal form. Resubmissions, where required, shall be in accordance with the procedures established for the initial submittal.

2.7.7 A preliminary schedule of values for all of the Work which will include quantities and prices of items aggregating the Contract Price and will sub-divide the Work into component parts in sufficient detail to serve as the basis for progress payments during construction. Such prices will include an appropriate amount of overhead and profit applicable to each item of Work which will be confirmed in writing by CONTRACTOR at the time of submission.

2.8 Before any Work at the site is started, CONTRACTOR shall deliver to DISTRICT, certificates and evidence of insurance requested by the DISTRICT which CONTRACTOR is required to purchase and maintain in accordance with paragraphs 5.3 – 5.10, and DISTRICT shall deliver to CONTRACTOR certificates (and other evidence of insurance requested by CONTRACTOR) which DISTRICT is required to purchase and maintain in accordance with paragraph .5.12.

Pre-construction Conference:

2.9 Within ten days after the Effective Date of the Agreement, but before CONTRACTOR starts the Work at the site, a pre-construction conference attended by CONTRACTOR, ENGINEER and others as appropriate will be held to discuss the schedules referred to in paragraph 2.7, to discuss procedures for handling Shop Drawings and other submittals and for processing Applications for Payment, and to establish a working understanding among the parties as to the Work.

Regular Working Hours:

2.10 All construction activities requiring inspection shall be carried out during regular working hours during normal working days being from 8:00 a.m. - 5:00 p.m., Monday through Friday, except for: New Year's Day, Martin Luther King's Birthday, Good Friday, Memorial Day, Independence Day, Labor Day, Thanksgiving Day and the Friday after, Christmas Day, and December 24 and 26 if they are not on a Saturday or Sunday. When holidays fall on weekends, other days will be observed as the holiday.

2.10.1 No inspections shall take place outside normal times without prior approval of the DISTRICT. Approval shall only be given in emergencies that affect the public health, safety and welfare.

2.10.2 All construction activities conducted outside normal times without prior approval of the DISTRICT shall subject the Work to uncovering for inspection. Said uncovering shall be at the CONTRACTOR'S expense.

Finalizing Schedules:

2.11 At least ten days before submission of the first Application for Payment a conference attended by CONTRACTOR, ENGINEER and others as appropriate will be held to finalize the schedules submitted in accordance with paragraph 2.6. The finalized progress schedule will be acceptable to ENGINEER as providing an orderly progression of the Work to completion within the Contract Time; but such acceptance will neither impose on ENGINEER responsibility for the progress or scheduling of the Work nor relieve

Rev 6 10

Section IV - General Conditions

CONTRACTOR from full responsibility therefore. The finalized schedule of Shop Drawing submission will be acceptable to ENGINEER as providing a workable arrangement for processing the submissions. The finalized schedule of values will be acceptable to ENGINEER as to form and substance.

ARTICLE 3--CONTRACT DOCUMENTS: INTENT, AMENDING, RE-USE

Intent:

3.1 The Contract Documents comprise the entire Agreement between DISTRICT and CONTRACTOR concerning the Work. The Contract Documents are complementary; what is called for by one is as binding as if called for by all. The Contract Documents will be construed in accordance with the laws of North Carolina.

3.2 It is the intent of the Contract Documents to describe a functionally complete Project (or part thereof) to be constructed in accordance with the Contract Documents. Any Work, materials or equipment that may reasonably be inferred from the Contract Documents as being required to produce the intended result will be supplied whether or not specifically called for. When words which have a generally accepted trade meaning are used to describe Work, materials or equipment, such words shall be interpreted in accordance with that meaning. Reference to standard specifications, manuals or codes of any technical society, organization or association, or to the Laws or Regulations of any governmental authority shall mean the latest standard specification, manual, code or Laws or Regulations in effect at the time of Opening of Bids (or on the Effective Date of the Agreement if there were no Bids), except as may be otherwise specifically stated. However, no provision of any referenced standard specification, manual or code (whether or not specifically incorporated by reference in the Contract Documents) shall be effective to change the duties and responsibilities of DISTRICT, CONTRACTOR or ENGINEER, or any of their consultants, agents or employees from those set forth in the Contract Documents, nor shall it be effective to assign to ENGINEER, or any of ENGINEER's consultants, agents or employees, any duty or authority to supervise or direct the furnishing or performance of the Work or any duty or authority to under take responsibility contrary to the provisions of paragraph 9.15 or 9.16. Clarifications and interpretations of the Contract Documents shall be issued by ENGINEER as provided in paragraph 9.5

3.3 If, during the performance of the Work, CONTRACTOR finds a conflict, error or discrepancy in the Contract Documents, CONTRACTOR shall so report to ENGINEER in writing at once and before proceeding with the Work affected thereby shall obtain a written interpretation or clarification from ENGINEER. However, CONTRACTOR shall not be liable to DISTRICT or ENGINEER for failure to report any conflict, error or discrepancy in the Contract Documents unless CONTRACTOR had actual knowledge thereof or should reasonably have been aware of such conflict, error or Discrepancy.

Amending and Supplementing Contract Documents:

3.4 The Contract Documents may be amended to provide for additions, deletions and revisions in the Work or to modify the terms and conditions thereof in one or more of the following ways:

- 3.4.1 A formal Written Amendment;
- 3.4.2 A Change Order (pursuant to paragraph 10.4); or
- 3.4.3 A Work Directive Change (pursuant to paragraph 10.1).

As indicated in paragraphs 11.2 and 12.1, Contract Price and Contract Time may only be changed by a Change Order or a Written Amendment.

Section IV - General Conditions

3.5 In addition, the requirements of the Contract Documents may be supplemented, and minor variations and deviations in the Work may be authorized, in one or more of the following ways:

3.5.1 A Field Order (pursuant to paragraph 9.5);

3.5.2 ENGINEER's approval of a Shop Drawing or sample (pursuant to paragraphs 6.26 and 6.27);
or

3.5.3 ENGINEER's written interpretation or clarification (pursuant to paragraph 9.4).

Re-use of Documents:

3.6 Neither CONTRACTOR nor any subcontractor or Supplier or other person or organization performing or furnishing any of the Work under a direct or indirect contract with DISTRICT shall have or acquire any title to or ownership rights in any of the Drawings, Specifications or other documents (or copies of any thereof) prepared by or bearing the seal of ENGINEER; and they shall not re-use any of them on extensions of the Project or any other project without written consent of DISTRICT and ENGINEER.

ARTICLE 4--AVAILABILITY OF LANDS, PHYSICAL CONDITIONS, REFERENCE POINTS

Availability of Lands:

4.1 DISTRICT shall provide access to the lands upon which the Work is to be performed, rights-of-way, easements and access to such other lands which are designated for the use of CONTRACTOR. Easements for permanent structures or permanent changes in existing facilities will be obtained and paid for by DISTRICT, unless otherwise provided in the Contract Documents. If CONTRACTOR believes that any delay in DISTRICT's furnishing these lands, rights-of-way or easements entitles CONTRACTOR to an extension of the Contract Time, CONTRACTOR may make a claim therefore as provided in Article 12. CONTRACTOR shall be responsible for all temporary construction facilities and space for storage of materials and equipment.

Physical Conditions:

4.2.1 Explorations and Reports: Reference is made to the Special Conditions for identification of those reports of explorations and tests of sub-surface conditions at the site that have been utilized by ENGINEER in preparation of the Contract Documents. CONTRACTOR may rely upon the accuracy of technical data contained in such reports; but not upon non-technical data, interpretations or opinions contained therein or for the completeness thereof for CONTRACTOR's purposes. Except as indicated in the immediately preceding sentence, CONTRACTOR shall have full responsibility with respect to sub-surface conditions at the site.

4.2.2 Existing Structures: Reference is made to the Special Conditions for identification of those drawings of physical conditions in or relating to existing surface and sub-surface structures (except Underground Facilities referred to in paragraph 4.3), which are at or contiguous to the site that have been utilized by ENGINEER in preparation of the Contract Documents. CONTRACTOR may rely upon the accuracy of the technical data contained in such drawings; but not for the completeness thereof for CONTRACTOR's purposes. Except as indicated in the immediately preceding sentence and in paragraph 4.2.6, CONTRACTOR shall have full responsibility with respect to physical conditions in or relating to such structures.

Section IV - General Conditions

4.2.3 Report of Differing Conditions: If CONTRACTOR believes that:

4.2.3.1 Any technical data on which CONTRACTOR is entitled to rely as provided in paragraphs 4.2.1 and 4.2.2 is inaccurate; or

4.2.3.2 Any physical condition uncovered or revealed at the site differs materially from that indicated, reflected or referred to in the Contract Documents.

CONTRACTOR shall promptly, after becoming aware thereof and before performing any Work in connection therewith (except in an emergency as permitted by paragraph 6.22), notify ENGINEER in writing about the inaccuracy or difference.

4.2.4 ENGINEER's Review: ENGINEER will promptly review the pertinent conditions, determine the necessity of obtaining additional explorations or tests with respect thereto, and send a copy to CONTRACTOR, of ENGINEER's findings and conclusions.

4.2.5 Possible Documents Change: If ENGINEER concludes that there is a material error in the Contract Documents or that because of newly discovered conditions a change in the Contract Documents is required, a Work Directive change or a Change Order will be issued as provided in Article 10 to reflect and document the consequences of the inaccuracy or difference.

4.2.6 Possible Price and Time Adjustment: In each such case, an increase or decrease in the Contract Price or an extension or shortening of the Contract Time, or any combination thereof, will be allowable to the extent that they are attributable to any such inaccuracy or difference. If DISTRICT and CONTRACTOR are unable to agree as to the amount or length thereof, a claim may be made therefor as provided in Articles 11 and 12.

Physical Conditions -- Underground Facilities:

4.3.1 Shown or Indicated: The information and data shown or indicated in the Contract Documents with respect to existing Underground Facilities at or contiguous to the site is based on information and data furnished to ENGINEER by the owners of such Underground Facilities or by others.

4.3.1.1 DISTRICT and ENGINEER shall not be responsible for the accuracy or completeness of any such information or data; and

4.3.1.2 CONTRACTOR shall have full responsibility for reviewing and checking all such information and data, for locating all Underground Facilities shown or indicated in the Contract Documents, for coordination of the Work with the owners of such Underground Facilities during construction, for the safety and protection thereof as provided in paragraph 6.20 and repairing any damage thereto resulting from the Work, the cost of all of which will be considered as having been included in the Contract Price.

4.3.2 Not Shown or Indicated: If an Underground Facility is uncovered or revealed at or contiguous to the site which was not shown or indicated in the Contract Documents and which CONTRACTOR could not reasonably have been expected to be aware of, CONTRACTOR shall, promptly after becoming aware thereof and before performing any Work affected thereby (except in an emergency as permitted by paragraph 6.22), identify the owner of such Underground Facility and give written notice thereof to that owner and to ENGINEER. ENGINEER will promptly review the Underground Facility to determine the extent to which it may be necessary to modify the Contract Documents to

Rev 6 10

Section IV - General Conditions

reflect the existence of the Underground Facility, and the Contract Documents will be amended or supplemented to the extent necessary. During such time, CONTRACTOR shall be responsible for the safety and protection of such Underground Facility as provided in paragraph 6.20. CONTRACTOR shall be allowed an increase in the Contract Price or an extension of the Contract Time, or both; to the extent that they are attributable to the existence of any Underground Facility that was not shown or indicated in the Contract Documents and which CONTRACTOR could not reasonably have been expected to be aware of. If the parties are unable to agree as to the amount or length thereof, CONTRACTOR may make a claim therefor as provided in Article 11 and 12.

Reference Points:

4.4 DISTRICT shall provide engineering surveys to establish reference points for construction which in ENGINEER's judgment are necessary to enable CONTRACTOR to proceed with the Work. CONTRACTOR shall be responsible for laying out the Work (unless otherwise specified in the General Requirements), shall protect and preserve the established reference points and shall make no changes or relocations without the prior written approval of ENGINEER. CONTRACTOR shall report to ENGINEER whenever any reference point is lost or destroyed or requires relocation because of necessary changes in grades or locations, and shall be responsible for the accurate replacement or relocation of such reference points by professionally qualified personnel.

ARTICLE 5--BONDS AND INSURANCE

Performance and Other Bonds:

5.1 CONTRACTOR shall furnish performance and payment Bonds, each in an amount at least equal to the Contract Price as security for the faithful performance and payment of all CONTRACTOR's obligations under the Contract Documents. These Bonds shall remain in effect at least until one year after the date when final payment becomes due, and shall be as prescribed by North Carolina General Statute 44A or by the Contract Documents. All Bonds shall be in the Forms prescribed by North Carolina General Statutes Chapter 44A or by the Contract Documents and be executed by sureties licensed to do business in North Carolina. All Bonds signed by an agent must be accompanied by a copy of the documents authorizing the agent to execute such Bonds.

5.2 If the surety on any bond furnished by CONTRACTOR is declared bankrupt or becomes insolvent or its right to do business is terminated in North Carolina or it otherwise ceases to meet the requirements of paragraph 5.1, CONTRACTOR shall within five days thereafter substitute another Bond acceptable to DISTRICT.

Insurance:

5.3 The CONTRACTOR shall provide adequate insurance to protect the CONTRACTOR, his Subcontractors, the DISTRICT, and the ENGINEER against damage claims which may arise out of or result from the execution of the work whether such execution be by the CONTRACTOR, by any Subcontractor, by anyone directly or indirectly employed by any of them, or by anyone for whose acts any of them may be liable with coverage and amounts not less than those set forth herewith. All Subcontractors under the CONTRACTOR, of whatever tier, shall provide the same insurance as that required of the CONTRACTOR in addition to that required of the CONTRACTOR.

5.4 The CONTRACTOR shall not commence work on the project until he has obtained all insurance required under this paragraph and such insurance has been accepted by the DISTRICT, nor shall the

Section IV - General Conditions

CONTRACTOR allow any Subcontractor to commence work until the insurance required of the Subcontractor has been obtained and accepted by the DISTRICT.

5.5 All insurance policies shall include a clause requiring that the policy shall not be canceled, modified, nor allowed to expire without 30 days written notice to DISTRICT.

5.6 The CONTRACTOR and Subcontractors shall furnish the DISTRICT a certificate or certificates of insurance issued by an insurance company duly licensed to engage in the business of insurance in North Carolina as evidence that the required insurance policies have been procured and are in force. Actual copies of the insurance policies shall be submitted to the DISTRICT within 10 days after submission of the certificates.

5.7 The CONTRACTOR and Subcontractors shall procure and maintain during the life of the contract the following Insurance:

5.7.1 General Liability and Property Damage Insurance in an amount not less than \$1,000,000 for all damages arising out of bodily injury, including death, sustained by any one person in any one accident, and subject to a \$2,000,000 aggregate limit, and not less than \$1,000,000 for all property damages sustained by any one person in any one occurrence, and subject to the same limit in aggregate. Added to the policy by endorsement shall be (1) Fellow Employee Insurance covering all employees; (2) Broad Form Comprehensive General Liability Insurance; and (3) Explosion (Blasting), Collapse, and Underground Hazard Insurance in the amounts shown above.

5.7.2 Excess General Liability and Property Damage Insurance, Automobile Liability and Employer Liability (Umbrella or Form Following Coverage Equal) in an amount not less than \$1,000,000 in aggregate to cover bodily injury, death, and property damage which shall apply as excess insurance over and above the General Liability, Property Damage, Automobile Liability and Employer Liability. Added to the policy by endorsement shall be (1) Fellow Employee Insurance covering all employees; (2) Broad Form Comprehensive General Liability Insurance; and (3) Explosion (Blasting), Collapse, and Underground Hazards Insurance in the amounts shown above.

5.7.3 Motor Vehicle Liability Insurance on all motor vehicles owned, leased, or otherwise used by the CONTRACTOR and all Subcontractors and employers non-ownership coverage for the CONTRACTOR and Subcontractors in an amount not less than \$1,000,000 each occurrence to include uninsured and underinsured motorist.

5.7.4 DISTRICT's Protective Liability and Property Damage Insurance to protect the DISTRICT or any of its employees, officers or agents, the ENGINEER, and such other engineer or engineers as may act under the contract, against claims arising from the operations of the CONTRACTOR or his Subcontractors. Such insurance shall be provided by endorsements to the General Liability and Property Damage Insurance, Excess General Liability and Property Damage Insurance, Motor Vehicle Liability Insurance, and Excess Motor Vehicle Liability Insurance policies (including all endorsements) or separate policies shall be provided. Coverage and amounts shall be the same as required of the CONTRACTOR.

5.7.5 Workers' Compensation Insurance as required by applicable Federal, State, or Territorial laws for all employees of the CONTRACTOR and employees of his Subcontractors in the event that the Subcontractors fail to provide such insurance. This insurance shall contain endorsements including (1) Broad Form All States Coverage, (2) United States Longshoremen's and Harbor Workers' Compensation Act, (3) Maritime or Jones Act coverage, when applicable, and (4) Voluntary Compensation Coverage, and shall specifically list the state where the work is performed.

Section IV - General Conditions

5.7.6 Employers Liability Insurance on all employees of the CONTRACTOR and employees of his Subcontractors in the event that the Subcontractors fail to provide such insurance. This insurance shall provide coverage of at least the statutory minimum requirements.

5.7.7 "Special Form" Type Builders Risk Insurance as will protect the CONTRACTOR and the DISTRICT from loss or damage while the project is under construction and prior to full acceptance thereof by the DISTRICT. The policies shall be payable to the CONTRACTOR and the DISTRICT as their interest in the facility may be determined. This provision shall not release the CONTRACTOR of his obligation to complete, according to the plans and specifications, the project covered by the contract, and the CONTRACTOR and his surety shall be obligated to full performance of the CONTRACTOR's undertaking. The policy coverage shall include all materials and supplies at any location and/or in transit, including theft, at the time an insurable interest begins. The policy shall contain no exclusion pertaining to water damage or any other damage of a building not fully enclosed.

5.7.8 Railroad Protective Liability and Property Damage Liability Insurance if operations performed by the CONTRACTOR require work to be done under, over, or within fifty (50) feet of the center line of any track of any railroad company, unless a written waiver is obtained by the CONTRACTOR from the office of the railroad company's division superintendent having jurisdiction. The CONTRACTOR shall furnish to the railroad company an original insurance policy covering the operations which will be performed by the CONTRACTOR or any Subcontractor, naming the railroad as insured, on the form of Railroad Protective Policy as accepted by the Association of American Railroads and Mutual Insurance Rating Bureau. The amounts and limits of such insurance shall be as required by the division superintendent of the railroad company.

Contractor's Liability Insurance:

5.8 CONTRACTOR shall purchase and maintain in force comprehensive general liability and other insurance as is appropriate for the Work being performed and furnished and will provide protection from claims of injury to persons or property arising out of the Work. In addition, CONTRACTOR shall maintain in force and provide certificates of coverage for:

5.8.1 workers' or workmen's compensation insurance as required by the laws of North Carolina.

5.8.2 liability insurance as required by law for all vehicles and machinery operated by CONTRACTOR in connection with the Work.

The insurance required by this paragraph shall include the specific coverages and be written for not less than the limits of liability and coverages provided below or required by law, whichever is greater. The comprehensive general liability insurance shall include completed operations insurance. All of the policies of insurance so required to be purchased and maintained (or the certificates or other evidence thereof) shall contain a provision or endorsement that the coverage afforded will not be canceled, materially changed or renewal refused until at least thirty days' prior written notice has been given to DISTRICT by certified mail. All such insurance shall remain in effect until final payment and at all times thereafter when CONTRACTOR may be correcting, removing or replacing **defective** Work in accordance with paragraph 13.11. In addition, CONTRACTOR shall maintain such completed operations insurance for at least two years after final payment and furnish DISTRICT with evidence of continuation of such insurance at final payment and one year thereafter. Further, CONTRACTOR shall be responsible for verifying that any and all Subcontractors

Rev 6 10

Section IV - General Conditions

furnishing labor and/or materials in connection with the Work be properly insured.

Contractual Liability Insurance:

5.9 In accordance with North Carolina General Statutes Chapter 22B-1, "The CONTRACTOR, to the extent permitted by law, hereby agrees to indemnify and hold harmless the DISTRICT, its independent contractors, agents, and employees against liability for damages resulting from the sole negligence of the CONTRACTOR, its agents or employees. For the purposes of this paragraph, damages shall include the cost and expense of defending a claim, the amount of any judgment recovered, and the amount of damage to property or person.

5.10 The comprehensive general liability insurance required by paragraph 5.8 will include contractual liability insurance applicable to CONTRACTOR's obligations under paragraphs 6.30 and 6.31.

District's Liability Insurance:

5.11 DISTRICT shall be responsible for purchasing and maintaining DISTRICT's own liability insurance and, at DISTRICT's option, may purchase and maintain such insurance as will protect DISTRICT against claims which may arise from operations under the Contract Documents.

Property Insurance:

5.12 CONTRACTOR shall purchase and maintain property insurance upon the Work at the site to the full insurable value thereof (subject to such deductible amounts as may be required by Laws and Regulations). The insurance shall include the interests of DISTRICT, CONTRACTOR, Subcontractors, and ENGINEER in the Work, all of whom shall be listed as insured or additional insured parties, shall insure against the perils of fire and extended coverage and shall include "all risk" insurance for physical loss and damage including theft, vandalism and malicious mischief, collapse and water damage, and shall include damages, losses and expenses arising out of or resulting from any insured loss or incurred in the repair or replacement of any insured property (including but not limited to fees and charges of engineers, architects, attorneys and other professionals). If independent consultants are hired, they shall be required to purchase and maintain in force insurance appropriate for the Work. If not covered under the "all risk" insurance CONTRACTOR shall purchase and maintain similar property insurance on portions of the Work stored on and off the site or in transit when such portions of the Work are to be included in an Application for Payment.

5.13 DISTRICT shall purchase and maintain such boiler and machinery insurance or additional property insurance as may be required by Laws and Regulations which will include the interest of DISTRICT, CONTRACTOR, Subcontractors, ENGINEER and ENGINEER'S consultants in the Work, all of whom shall be listed as insured or additional insured parties.

5.14 All the policies of insurance (or the certificates or other evidence thereof) required to be purchased and maintained by DISTRICT in accordance with paragraphs 5.12 will contain a provision or endorsement that the coverage afforded will not be canceled or materially changed or renewal refused until at least thirty days' prior written notice has been given to CONTRACTOR by certified mail and will contain waiver provisions in accordance with paragraph 5.18.1

5.15 DISTRICT shall not be responsible for purchasing and maintaining any property insurance to protect the interest of CONTRACTOR, Subcontractors or others in the Work to the extent of any deductible amounts that are provided. The risk of loss within the deductible amount, will be borne by CONTRACTOR, Subcontractor or others suffering any such loss and if any of them wishes property insurance coverage within

Section IV - General Conditions

the limits of such amounts, each may purchase and maintain it at the purchaser's own expense.

5.16 If CONTRACTOR requests in writing that other special insurance be included in the property insurance policy, DISTRICT shall, if possible, include such insurance, and the cost thereof will be charged to CONTRACTOR by appropriate Change Order or Written Amendment. Prior to commencement of the Work at the site, DISTRICT shall in writing advise CONTRACTOR whether or not such other insurance has been procured by DISTRICT.

Waiver of Rights:

5.17.1 DISTRICT and CONTRACTOR waive all right against each other for all losses and damages caused by any of the perils covered by the policies of insurance provided in response to paragraph 5.12 and any other property insurance applicable to the Work, and also waive all such rights against the Subcontractor, ENGINEER, ENGINEER's consultants and all other parties named as insured in such policies for losses and damages so caused. As required by paragraph 6.11, each subcontract between CONTRACTOR and a Subcontractor will contain similar waiver provisions by the Subcontractor in favor of DISTRICT, CONTRACTOR, ENGINEER, ENGINEER's consultants and all other parties named as insured. None of the above waivers shall extend to the rights that any of the insured parties may have to the proceeds of insurance held by DISTRICT as trustee or otherwise payable under any policy so issued.

5.17.2 DISTRICT and CONTRACTOR intend that any policies provided in response to paragraph 5.12 shall protect all of the parties insured and provide primary coverage for all losses and damages caused by the perils covered thereby. Accordingly, all such policies shall contain provisions to the effect that in the event of payment of any loss or damage the insurer will have not rights of recovery against any of the parties named as insured or additional insured, and if the insurers require separate waiver forms to be signed by ENGINEER or ENGINEER'S 's consultant DISTRICT will obtain the same, and if such waiver forms are required of any Subcontractor, CONTRACTOR will obtain the same.

Receipt and Application of Proceeds:

5.18 Any insured loss under the policies of insurance required by paragraph 5.12 will be adjusted with DISTRICT and made payable to DISTRICT as trustee for the insured, as their interests may appear, subject to the requirements of any applicable mortgage clause and of paragraph 5.19 . DISTRICT shall deposit in a separate account any money so received, and shall distribute it in accordance with such agreement as the parties in interest may reach. If no other special agreement is reached the damaged Work shall be repaired or replaced, the monies so received applied on account thereof and the Work and the cost thereof covered by an appropriate Change Order or Written Amendment.

5.19 DISTRICT as trustee shall have power to adjust and settle any loss with the insurers unless one of the parties in interest shall object in writing within fifteen days after the occurrence of loss to DISTRICT's exercise of this power. If such objection be made, DISTRICT as trustee shall make settlement with the insurers in accordance with such agreement as the parties in interest may reach. If required in writing by any party in interest, DISTRICT as trustee shall, upon the occurrence of an insured loss, give bond for the proper performance of such duties.

Acceptance of Insurance:

5.20 If DISTRICT has any objection to the coverage afforded by or other provisions of the insurance

Section IV - General Conditions

required to be purchased and maintained by CONTRACTOR in accordance with paragraphs 5.3 – 5.10 on the basis of its not complying with the Contract Documents, DISTRICT shall notify CONTRACTOR in writing thereof within ten days of the date of delivery of such certificates to DISTRICT in accordance with paragraph 2.8. If CONTRACTOR has any objection to the coverage afforded by or other provisions of the policies of insurance required to be purchased and maintained by DISTRICT on the basis of their not complying with the Contract Documents, CONTRACTOR shall notify DISTRICT in writing thereof within ten days of the date of delivery of such certificates to CONTRACTOR in accordance with paragraph 2.8, DISTRICT and CONTRACTOR shall each provide to the other such additional information in respect of insurance provided by each as the other may reasonably request. Failure by DISTRICT or CONTRACTOR to give any such notice of objection within the time provided shall constitute acceptance of such insurance purchased by the other as complying with the Contract Documents.

Partial Utilization - Property Insurance:

5.21 If DISTRICT finds it necessary to occupy or use a portion or portions of the Work prior to Substantial Completion of all the Work, such use or occupancy may be accomplished in accordance with paragraph 14.10, provided that no such use or occupancy shall commence before the insurers providing the property insurance have acknowledged notice thereof and in writing effected the changes in coverage necessitated thereby. The insurers providing the property insurance shall consent by endorsement on the policy or policies, but the property insurance shall not be canceled or lapse on account of any such partial use or occupancy.

ARTICLE 6--CONTRACTOR'S RESPONSIBILITIES

Supervision and Superintendence:

6.1 CONTRACTOR shall supervise and direct the Work competently and efficiently, devoting such attention thereto and applying such skills and expertise as may be necessary to perform the Work in accordance with the Contract Documents. CONTRACTOR shall be solely responsible for the means, methods, techniques, sequences and procedures of construction; but CONTRACTOR shall not be responsible for the negligence of others in the design or selection of specific means, method, technique, sequence or procedure of construction which is indicated in and required by the Contract Documents. CONTRACTOR shall be responsible to see that the finished Work complies with the Contract Documents.

6.2 CONTRACTOR shall keep on the Work site at all times during its progress a competent resident superintendent, who shall not be replaced without written notice to DISTRICT and ENGINEER except under extraordinary circumstances. The superintendent will be CONTRACTOR's representative at the site and shall have authority to act on behalf of CONTRACTOR. All communications given to the superintendent shall be as binding as if given to CONTRACTOR.

Labor, Materials and Equipment:

6.3 CONTRACTOR shall provide competent, suitably qualified personnel to survey and lay out the Work and perform construction as required by the Contract Documents. CONTRACTOR shall at all times maintain good discipline and order at the site. Except in connection with the safety or protection of persons or the Work or property at the site or adjacent thereto, and except as otherwise indicated in the Contract Documents, all Work at the site shall be performed during regular working hours, and CONTRACTOR will not permit overtime work or the performance of Work on Saturday, Sunday or any legal holiday without DISTRICT'S written consent.

6.4 Unless otherwise specified in the General Requirements, CONTRACTOR shall furnish and assume full

Section IV - General Conditions

responsibility for all materials, equipment, labor, transportation, construction equipment and machinery, tools, appliances, fuel, power, light, heat, telephone, water, sanitary facilities, temporary facilities and all other facilities and incidentals necessary for the furnishing, performance, testing, start-up and completion of the Work.

6.5 All materials and equipment shall be of good quality and new, except as otherwise provided in the Contract Documents. If required by ENGINEER, CONTRACTOR shall furnish satisfactory evidence (including reports of required tests) as to the kind and quality of materials and equipment. All materials and equipment shall be applied, installed, connected, erected, used, cleansed and conditioned in accordance with the instructions of the applicable Supplier except as otherwise provided in the Contract Documents; but no provision of any such instructions will be effective to assign to ENGINEER any duty or authority to supervise or direct the furnishing or performance of the Work or any duty or authority to undertake responsibility contrary to the provisions of paragraph 9.15 or 9.16.

Adjusting Progress Schedule:

6.6 CONTRACTOR shall submit to ENGINEER for acceptance adjustments in the progress schedule to reflect the impact thereon of new developments; these will conform generally to the progress schedule then in effect and additionally will comply with any provisions of the General Requirements applicable thereto.

Substitutes or "Or-Equal" Items:

6.7.1 Whenever materials or equipment are specified or described in the Contract Documents by using the name of a proprietary item, it is intended to establish the type, function and quality required. Unless the name is followed by words indicating that no substitution is permitted, materials or equipment of other Suppliers may be accepted by ENGINEER if sufficient information is submitted by CONTRACTOR to allow ENGINEER to determine that the material or equipment proposed is equivalent or equal to that named.

6.7.2 The procedure for review by ENGINEER will include the following as supplemented in the General Requirements. Requests for review of substitute items of material and equipment will not be accepted by ENGINEER from anyone other than CONTRACTOR. If CONTRACTOR wishes to furnish or use a substitute item of material or equipment, CONTRACTOR shall make written application to ENGINEER for acceptance thereof, certifying that the proposed substitute will perform adequately the functions and achieve the results called for by the general design, be similar and of equal substance to that specified and be suited to the same use as that specified. The application will state that the evaluation and acceptance of the proposed substitute will not prejudice CONTRACTOR's achievement of Substantial Completion on time, whether or not acceptance of the substitute for use in the Work will require a change in any of the Contract Documents (or in the provisions of any other direct contact with DISTRICT for work on the Project) to adapt the design to the proposed substitute and whether or not incorporation or use of the substitute in connection with the Work is subject to payment of any license fee or royalty. All variations of the proposed substitute from that specified will be identified in the application and available maintenance, repair and replacement service will be indicated. The application will also contain an itemized estimate of all costs that will result directly or indirectly from acceptance of such substitute, including costs of re-design and claims of other contractors affected by the resulting change, all of which shall be considered by ENGINEER in evaluating the proposed substitute, ENGINEER may require CONTRACTOR to furnish at CONTRACTOR's expense additional data about the proposed substitute.

Section IV - General Conditions

6.7.3 If a specific means, method, technique, sequence or procedure of construction is indicated in or required by the Contract Documents, CONTRACTOR may furnish or utilize a substitute means, method, sequence, technique or procedure of construction acceptable to ENGINEER, if CONTRACTOR submits sufficient information to allow ENGINEER to determine that the substitute proposed is equivalent to that indicated or required by the Contract Documents. The procedure for review by ENGINEER will be similar to that provided in paragraph 6.7.1 as applied by ENGINEER and as may be supplemented in the General Requirements.

6.7.4 ENGINEER will be allowed a reasonable time within which to evaluate each proposed substitute. ENGINEER will be the sole judge of acceptability, and no substitute will be ordered, installed or utilized without ENGINEER's prior written acceptance which will be evidenced by either a Change Order or an approved Shop Drawing, DISTRICT may require CONTRACTOR to furnish at CONTRACTOR's expense a special performance guarantee or other surety with respect to any substitute. ENGINEER will record time required by ENGINEER and ENGINEER's consultants in evaluating substitutions proposed by CONTRACTOR and in making changes in the Contract Documents occasioned thereby. Whether or not ENGINEER accepts a proposed substitute, CONTRACTOR shall reimburse DISTRICT for the charges of ENGINEER and ENGINEER's consultants for evaluating each proposed substitute.

Concerning Subcontractors, Suppliers and Others:

6.8.1 CONTRACTOR shall not employ any Subcontractor, Supplier or other person or organization whether initially or as a substitute, against whom ENGINEER may have reasonable objection. CONTRACTOR shall not be required to employ any Subcontractor, Supplier or other person or organization to furnish or perform any of the Work against whom CONTRACTOR has reasonable objection.

6.8.2 If the General Conditions require the identity of certain Subcontractors, Suppliers or other persons or organizations (including those who are to furnish the principal items of materials and equipment) to be submitted to DISTRICT in advance of the specified date prior to the Effective Date of the Agreement for acceptance by DISTRICT and if CONTRACTOR has submitted a list thereof in accordance with the General Conditions, ENGINEER's acceptance (either in writing or by failing to make written objection thereto by the date indicated for acceptance or objection in the bidding documents or the Contract Documents) of any such Subcontractor, Supplier or other person or organization so identified may be revoked on the basis of reasonable objection after due investigation, in which case CONTRACTOR shall submit an acceptable substitute, the Contract Price will be increased by the difference in the cost occasioned by such substitution and an appropriate Change Order will be issued or Written Amendment signed. No acceptance by ENGINEER of any such Subcontractor, Supplier or other person or organization shall constitute a waiver of any right of DISTRICT or ENGINEER to reject "defective" Work.

6.9 CONTRACTOR shall be fully responsible to DISTRICT for all acts and omissions of the Subcontractors, Suppliers and other persons and organizations performing or furnishing any of the Work under a direct or indirect contract with CONTRACTOR just as CONTRACTOR is responsible for CONTRACTOR's own acts and omissions. Nothing in the Contract Documents shall create any contractual relationship between DISTRICT and any such Subcontractor, Supplier or other person or organization, nor shall it create any obligation on the part of DISTRICT to pay or to see to the payment of any monies due any such Subcontractor, Supplier or other person or organization except as may otherwise be required by Laws and Regulations.

Section IV - General Conditions

6.10 The divisions and sections of the Specifications and the identifications of any Drawings shall not control CONTRACTOR in dividing the Work among Subcontractors or Suppliers or delineating the Work to be performed by any specific trade.

6.11 All Work performed for CONTRACTOR by a Subcontractor will be pursuant to an appropriate agreement between CONTRACTOR and the Subcontractor which specifically binds the Subcontractor to the applicable terms and conditions of the Contract Documents for the benefit of DISTRICT and contains waiver provisions as required by paragraph 5.17. CONTRACTOR shall pay each Subcontractor a just share of any insurance monies received by CONTRACTOR on account of losses under policies issued pursuant to paragraph 5.15.

Patent Fees and Royalties:

6.12 CONTRACTOR shall pay all license fees and royalties and assume all costs incident to the use in the performance of the Work or the incorporation in the Work of any invention, design, process, product or device which is the subject of patent rights or copyrights held by others. If a particular invention, design, process, product or device is specified in the Contract Documents for use in the performance of the Work and if to the actual knowledge of ENGINEER its use is subject to patent rights or copyrights calling for the payment of any license fee or royalty to others, the existence of such rights shall be disclosed by DISTRICT in the Contract Documents. CONTRACTOR shall indemnify and hold harmless DISTRICT and ENGINEER and anyone directly or indirectly employed by either of them from and against all claims, damages, losses and expenses (including attorney's fees and court and appeals costs) arising out of any infringement of patent rights or copyrights incident to the use in the performance of the Work or resulting from the incorporation in the Work of any invention, design, process, product or device not specified in the Contract Documents, and shall defend all such claims in connection with any alleged infringement of such rights.

Permits:

6.13 CONTRACTOR shall obtain and pay for all permits and licenses necessary to do the work, which have not been obtained by DISTRICT. DISTRICT shall assist CONTRACTOR, when necessary, in obtaining such permits and licenses. CONTRACTOR shall post all bonds, provide all insurance, pay all governmental charges, pay all fees, provide all warranties required for the prosecution of the WORK which are applicable at the time of opening Bids, or if there are no Bids, on the Effective Date of the Agreement. CONTRACTOR shall pay all charges of such utility owners for capital costs related thereto, and CONTRACTOR shall be responsible for all notifications and acceptances required of all permits.

Laws and Regulations:

6.14.1 CONTRACTOR shall give all notices and comply with all Laws and Regulations applicable to furnishing and performance of the Work. Except where otherwise expressly required by applicable Laws and Regulations, neither DISTRICT nor ENGINEER shall be responsible for monitoring CONTRACTOR's compliance with any Laws or Regulations.

6.14.2 If CONTRACTOR observes that the Specifications or Drawings are at variance with any Laws or Regulations, CONTRACTOR shall give ENGINEER prompt written notice thereof, and any necessary changes will be authorized by one of the methods indicated in paragraph 3.4. If CONTRACTOR performs any work knowing or having reason to know that it is contrary to such Laws or Regulations, and without such notice to ENGINEER, CONTRACTOR shall bear all costs arising therefrom; however, it shall not be CONTRACTOR's primary responsibility to make certain that the Specifications and Drawings are in accordance with such Laws and Regulations.

Section IV - General Conditions

Taxes:

6.15 CONTRACTOR shall pay all sales, consumer, use and other similar taxes required to be paid by CONTRACTOR in accordance with the laws and regulations of the place of the Project which are applicable during the performance of the Work.

Use of Premises:

6.16 CONTRACTOR shall confine construction equipment, the storage of materials and equipment and the operations of workers to the Project site and land and areas identified in and permitted by the Contract Documents and other land and areas permitted by Laws and Regulations, rights-of-way, permits and easements, and shall not unreasonably encumber the premises with construction equipment or other materials or equipment. CONTRACTOR shall assume full responsibility for any damage to any such land or area, or to the owner or occupant thereof or of any land or areas contiguous thereto, resulting from the performance of the Work. Should any claim be made against DISTRICT by any such owner or occupant because of the performance of the Work, CONTRACTOR shall promptly attempt to settle with such other party by agreement or otherwise resolve the claim. CONTRACTOR shall indemnify and hold DISTRICT and ENGINEER harmless from and against all claims for injury to persons or property including legal fees and other professional fees arising out of the Work.

6.17 During the progress of the Work, CONTRACTOR shall keep the premises free from accumulations of waste materials, rubbish and other debris resulting from the Work. At the completion of the Work, CONTRACTOR shall remove all waste materials, rubbish and debris from and about the premises as well as all tools, appliances, construction equipment and machinery, and surplus materials, and shall leave the site clean and ready for occupancy by DISTRICT. CONTRACTOR shall restore to original condition all property not designated for alteration by the Contract Documents.

6.18 CONTRACTOR shall not load nor permit any part of any structure to be loaded in any manner that will endanger the structure, nor shall CONTRACTOR subject any part of the Work or adjacent property to stresses or pressures that will endanger it.

Record Documents:

6.19 CONTRACTOR shall maintain in a safe place at the site one record copy of all Drawings, Specifications, Addenda, Written Amendments, Change Orders, Work Directive Changes, Field Orders and written interpretations and clarifications (issued pursuant to paragraph 9.4) in good order and annotated to show all changes made during construction. These record documents together with all approved samples and a counterpart of all approved Shop Drawings will be available to ENGINEER for reference. Upon completion of the Work, these record documents, samples and Shop Drawings will be delivered to ENGINEER.

Safety and Protection:

6.20 CONTRACTOR shall be responsible for initiating, maintaining and supervising all safety precautions and programs in connection with the Work. CONTRACTOR shall take all necessary precautions for the safety of, and shall provide the necessary protection to prevent damage, injury or loss to:

6.20.1 all employees on the Work and other persons and organizations who may be affected thereby;

6.20.2 all the Work and materials and equipment to be incorporated therein, whether in storage on or

Rev 6 10

Section IV - General Conditions

off the site; and

6.20.3 other property at the site or adjacent thereto, including trees, shrubs, lawns, walks, pavements, roadways, structures, utilities and Underground Facilities not designated for removal, relocation or replacement in the course of construction.

CONTRACTOR shall comply with all applicable Laws and Regulations of any public body having jurisdiction for the safety of persons or property or to protect them from damage, injury or loss; and shall erect and maintain all necessary safeguards for such safety and protection. CONTRACTOR shall notify owners of adjacent property and of Underground Facilities and utility owners when prosecution of the Work may affect them, and shall cooperate with them in the protection, removal, relocation and replacement of their property. All damage, injury or loss to any property referred to in paragraph 6.20.2 or 6.20.3 caused, directly or indirectly, in whole or in part, by CONTRACTOR, any Subcontractor, Supplier or any other person or organization directly or indirectly employed by any of them to perform or furnish any of the Work or anyone for those acts any of them may be liable, shall be remedied by CONTRACTOR (except damage or loss attributable to the fault of Drawings or Specifications or to the acts or omissions of DISTRICT or ENGINEER or anyone employed by either of them or anyone for whose acts either of them may be liable, and not attributable, directly or indirectly, in whole or in part, to the fault or negligence of CONTRACTOR). CONTRACTOR's duties and responsibilities for the safety and protection of the Work shall continue until such time as all the Work is completed and ENGINEER has issued a notice to DISTRICT and CONTRACTOR in accordance with paragraph 14.13 that the Work is acceptable (except as otherwise expressly provided in connection with Substantial Completion).

6.21 CONTRACTOR shall designate a responsible representative at the site whose duty shall be the prevention of accidents. This person shall be CONTRACTOR's superintendent unless otherwise designated in writing by CONTRACTOR to DISTRICT.

Emergencies:

6.22 In emergencies affecting the safety or protection of persons or the Work or property at the site or adjacent thereto, CONTRACTOR, without special instruction or authorization from ENGINEER or DISTRICT, is obligated to act to prevent threatened damage, injury or loss, CONTRACTOR shall give ENGINEER prompt written notice if CONTRACTOR believes that any significant changes in the Work or variations from the Contract Documents have been caused thereby. If ENGINEER determines that a change in the Contract Documents is required because of the action taken in response to an emergency, a Work Directive Change or Change Order will be issued to document the consequences of the changes or variations.

Shop Drawings and Samples:

6.23 After checking and verifying all field measurements and after complying with applicable procedures specified in the General Requirements, CONTRACTOR shall submit to ENGINEER for review and approval in accordance with the accepted schedule of Shop Drawing submissions (see paragraph 2.11) five copies (unless otherwise specified in the General Requirements) of all Shop Drawings, which will bear a stamp or specific written indication that CONTRACTOR has satisfied CONTRACTOR's responsibilities under the Contract Documents with respect to the review of the submission. All submissions will be identified as ENGINEER may require. The data shown on the Shop Drawings will be complete with respect to quantities, dimensions, specified performance and design criteria, materials and similar data to enable ENGINEER to review the information as required.

6.24 CONTRACTOR shall also submit to ENGINEER for review and approval with such promptness as to

Rev 6 10

Section IV - General Conditions

cause no delay in Work, all samples required by the Contract Documents. All samples will have been checked by and accompanied by a specific written indication that CONTRACTOR has satisfied CONTRACTOR's responsibilities under the Contract Documents with respect to the review of the submission and will be identified clearly as to material, Supplier, pertinent data such as catalog numbers and the use for which intended.

6.25.1 Before submission of each Shop Drawing or sample, CONTRACTOR shall have determined and verified all quantities, dimensions, specified performance criteria, installation requirements, materials, catalog numbers and similar data with respect thereto and reviewed or coordinated each Shop Drawing or sample with other Shop Drawings and samples and with the requirements of the Work and the Contract Documents.

6.25.2 At the time of each submission, CONTRACTOR shall give ENGINEER specific written notice of each variation that the Shop Drawings or samples may have from the requirements of the Contract Documents, and in addition, shall cause a specific notation to be made on each Shop Drawing submitted to ENGINEER for review and approval of each such variation.

6.26 ENGINEER will review and approve with reasonable promptness Shop Drawings and samples; but ENGINEER's review and approval will be only for conformance with the design concept of the Project and for compliance with the information given in the Contract Documents and shall not extend to means, methods, techniques, sequences or procedures of construction (except where as specific means, method, technique, sequence or procedure of construction is indicated in or required by the Contract Documents) or to safety precautions or programs incident thereto. The review and approval of a separate item as such will not indicate approval of the assembly in which the item functions. CONTRACTOR shall make corrections required by ENGINEER, and shall return the required number of corrected copies of Shop Drawings and submit as required new samples for review and approval. CONTRACTOR shall direct specific attention in writing to revisions other than the corrections called for by ENGINEER on previous submittals.

6.27 ENGINEER's review and approval of Shop Drawings or samples shall not relieve CONTRACTOR from responsibility for any variation from the requirements of the Contract Documents unless CONTRACTOR has in writing called ENGINEER's attention to each such variation at the time of submission as required by paragraph 6.25.2 and ENGINEER has given written approval of each such variation by a specific written notation thereof incorporated in or accompanying the Shop Drawing or sample approval; nor will any approval by ENGINEER relieve CONTRACTOR from responsibility for errors or omissions in the Shop Drawings or from responsibility for having complied with the provisions of paragraph 6.25.1.

6.28 Where a Shop Drawing or sample is required by the Specifications, any related Work performed prior to ENGINEER's review and approval of the pertinent submission will be the sole expense and responsibility of CONTRACTOR.

Continuing the Work:

6.29 CONTRACTOR shall carry on the Work and adhere to the progress schedule during all disputes or disagreements with DISTRICT. No Work shall be delayed or postponed pending resolution of any disputes or disagreements, except as permitted by paragraph 15.5 or as CONTRACTOR and DISTRICT may otherwise agree in writing.

Indemnification:

6.30 CONTRACTOR shall indemnify and hold harmless DISTRICT and ENGINEER and their

Section IV - General Conditions

consultants, agents and employees from and against all claims, damages, losses and expenses, direct, indirect or consequential (including but not limited to fees and charges of engineers, architects, attorneys and other professionals and court and appeals costs) arising out of or resulting from the performance of the Work, provided that any such claim, damage, loss or expense (a) is attributable to bodily injury, sickness, disease or death, or to injury to or destruction of tangible property (other than the Work itself) including the loss of use resulting therefrom and (b) is caused in whole or in part by any negligent act or omission of CONTRACTOR, any Subcontractor, any person or organization directly or indirectly employed by any of them to perform or furnish any of the Work or anyone for whose acts any of them may be liable, regardless of whether or not it is caused in part by a party indemnified here under or arises by or is imposed by Law and Regulations regardless of the negligence of any such party.

6.31 In any and all claims against DISTRICT or ENGINEER or any of their consultants, agents or employees by any employee of CONTRACTOR, any Subcontractor, any person or organization directly or indirectly employed by any of them to perform or furnish any of the Work or anyone for whose acts any of them may be liable, the indemnification obligation under paragraph 6.30 shall not be limited in any way by any limitation on the amount or type of damages, compensation or benefits payable by or for CONTRACTOR or any such Subcontractor or other person or organization under workers or workmen's compensation acts, disability benefit acts or other employee benefit acts.

6.32 The obligations of CONTRACTOR under paragraph 6.30 shall not extend to the liability of ENGINEER, ENGINEER's consultants, agents or employees arising out of the preparation or approval of maps, drawings, opinions, reports, surveys, Change Orders, designs or specifications.

ARTICLE 7--OTHER WORK

Related Work at Site:

7.1 DISTRICT may perform other work related to the Project at the site by DISTRICT's own forces, have other work performed by utility owners or let other direct contracts therefor which shall contain General Conditions similar to these. If the fact that such other work is to be performed was noted in the Contract Documents, written notice thereof will be given to CONTRACTOR prior to starting any such other work; and if CONTRACTOR believes that such performance will involve additional expense to CONTRACTOR or requires additional time and the parties are unable to agree as to the extent thereof, CONTRACTOR may make a claim therefor as provided in Articles 11 and 12.

7.2 CONTRACTOR shall afford each utility owner and other contractor who is a party to such a separate contract (or DISTRICT, if DISTRICT is performing the additional work with DISTRICT's employees) proper and safe access to the site for the introduction and storage of materials and equipment and the execution of such work, and shall properly connect and coordinate the Work with theirs. CONTRACTOR shall do all cutting, fitting and patching of the Work that may be required to make its several parts come together properly and integrate with such other work. CONTRACTOR shall not endanger any work of others by cutting, excavating or otherwise altering their work and will only cut or alter their work with the written consent of ENGINEER and the others whose work will be affected. The duties and responsibilities of CONTRACTOR under this paragraph are for the benefit of such utility Districts and other contractors to the extent that there are comparable provisions for the benefit of CONTRACTOR in said separate contacts between DISTRICT and such utility owners and other contractors.

7.3 If any part of CONTRACTOR's Work depends for proper execution or results upon the work of any such other contractor or utility owner, CONTRACTOR shall inspect and promptly report to ENGINEER in writing any delays, defects or deficiencies in such work that render it unavailable or unsuitable for such proper

Section IV - General Conditions

execution and results. CONTRACTOR's failure to so report will constitute an acceptance of the other work as fit and proper for integration with CONTRACTOR's Work except for latent or non-apparent defects and deficiencies in the other work.

Coordination:

7.4 If DISTRICT contracts with others for the performance of other work on the Project at the site, the person or organization who will have authority and responsibility for coordination of the activities among the various prime Contractors will be identified in the Special Conditions, and the specific matters to be covered by such authority and responsibility will be itemized, and the extent of such authority and responsibilities will be provided in the Special Conditions. Unless otherwise provided in the Special Conditions, neither DISTRICT nor ENGINEER shall have any authority or responsibility in respect of such coordination.

ARTICLE 8--DISTRICT'S RESPONSIBILITIES

8.1 DISTRICT shall issue all communications to CONTRACTOR through ENGINEER.

8.2 In case of termination of the employment of ENGINEER, DISTRICT shall appoint an engineer, against whom CONTRACTOR makes no reasonable objection, whose status under the Contract Documents shall be that of the former ENGINEER.

8.3 DISTRICT shall furnish the data required of DISTRICT under the Contract Documents promptly and shall make payments to CONTRACTOR promptly after they are due as provided in paragraphs 14.4 and 14.13.

8.4 DISTRICT's duties in respect of providing lands and easements and providing engineering surveys to establish reference points are set forth in paragraphs 4.1 and 4.4. Paragraph 4.2 refers to DISTRICT's identifying and making available to CONTRACTOR copies of reports of explorations and tests of subsurface conditions at the site and in existing structures which have been utilized by ENGINEER in preparing the Plans and Specifications.

8.5 DISTRICT's responsibilities in respect of purchasing and maintaining liability and property insurance are set forth in paragraphs 5.3 through 5.9.

8.6 DISTRICT is obligated to execute Change Orders as indicated in paragraph 10.4.

8.7 DISTRICT's responsibility in respect of certain inspections, tests and approvals is set forth in paragraph 13.4.

8.8 In connection with DISTRICT's right to stop Work or suspend Work, see paragraphs 13.10 and 15.1. Paragraph 15.2 deals with DISTRICT's right to terminate services of CONTRACTOR under certain circumstances.

ARTICLE 9 -- ENGINEER'S STATUS DURING CONSTRUCTION

DISTRICT's Representative:

9.1 ENGINEER will be DISTRICT's representative during the construction period. The duties and responsibilities and the limitations of authority of ENGINEER as DISTRICT's representative during construction are set forth in the Contract Documents and shall not be extended without written consent of

Section IV - General Conditions

DISTRICT and ENGINEER.

Visits to Site:

9.2 ENGINEER will make visits to the site at intervals appropriate to the various stages of construction to observe the progress and quality of the executed Work and to determine, in general, if the Work is proceeding in accordance with the Contract Documents. ENGINEER will not be required to make exhaustive or continuous on-site inspections to check the quality or quantity of the Work. ENGINEER's efforts will be directed toward providing for DISTRICT a greater degree of confidence that the completed Work will conform to the Contract Documents. On the basis of such visits and on-site observations as an experienced and qualified design professional, ENGINEER will keep DISTRICT informed of the progress of the Work and will endeavor to guard DISTRICT against defects and deficiencies in the Work.

Project Representation:

9.3 An inspector shall be assigned to the Project by the DISTRICT, to serve as ENGINEER's representative. The inspector shall conduct inspections of the Work, materials, and tests for compliance with the approved Plans and Specifications. Such inspections shall take place during normal times with the CONTRACTOR providing safe access to the work.

9.3.1 The inspector shall attend the preconstruction meeting.

9.3.2 The inspector shall report to the ENGINEER the progress and compliance status of the Work.

9.3.3 Non-compliance issues shall be reported to the CONTRACTOR and ENGINEER.

9.3.4 Failure to obtain compliance by reporting non-compliance issues shall result in a final decision being rendered by the ENGINEER.

9.3.5 Until compliance is obtained based on the final decision of the ENGINEER, no inspections of Work other than the correction work required by the final decision shall take place. All other Work placed during this period shall be rejected.

9.3.6 The CONTRACTOR shall notify the inspector one day in advance prior to covering the Work that requires inspection or testing. Failure to notify the inspector of the need for inspection shall result in rejection of the Work.

9.3.7 Failure of the inspector to inspect when notified does not relieve the CONTRACTOR from compliance with the requirements of the Plans and Specifications.

9.3.8 The inspector is not authorized to revoke, alter or waive any requirements of the Contract Documents. Any advice or recommendation given by the inspector shall not be construed as releasing any party from the requirements of the approved Plans and Specifications.

9.3.9 The CONTRACTOR shall notify the inspector two days in advance to request a final inspection of the Work.

Clarifications and Interpretations:

Section IV - General Conditions

9.4 ENGINEER will issue with reasonable promptness such written clarifications or interpretations of the requirements of the Contract Documents (in the form of Drawings or otherwise) as ENGINEER may determine necessary, which shall be consistent with or reasonably inferable from the overall intent of the Contract Documents. If CONTRACTOR believes that a written clarification or interpretation justifies an increase in the Contract Price or an extension of the Contract Time and the parties are unable to agree to the amount or extent thereof, CONTRACTOR may make a claim therefor as provided in Article 11 or Article 12.

Authorized Variations in Work:

9.5 ENGINEER may authorize minor variations in the Work from the requirements of the Contract Documents which do not involve an adjustment in the Contract price or the Contract Time and are consistent with the overall intent of the Contract Documents. These may be accomplished by a Field Order and will be binding on DISTRICT, and also on CONTRACTOR who shall perform the Work involved promptly. If CONTRACTOR believes that a Field Order justifies an increase in the Contract Price or an extension of the Contract Time and the parties are unable to agree as to the amount or extent thereof, CONTRACTOR may make a claim therefore as provided in Article 11 or 12.

Rejecting Defective Work:

9.6 ENGINEER will have authority to disapprove or reject Work which ENGINEER believes to be "defective", and will also have authority to require special inspection or testing of the Work as provided in paragraph 13.9, whether or not the work is fabricated, installed or completed.

Shop Drawings, Change Orders and Payments:

9.7 In connection with ENGINEER's responsibility for Shop Drawings and samples, see paragraphs 6.23 through 6.28 inclusive.

9.8 In connection with ENGINEER's responsibilities as to Change Orders, see Articles 10, 11 & 12.

9.9 In connection with ENGINEER's responsibilities in respect of Applications for Payments, etc., see Article 14.

Determinations for Unit Prices:

9.10 ENGINEER will determine the actual quantities and classifications of Unit Price Work performed by CONTRACTOR. ENGINEER will review with CONTRACTOR preliminary determinations on such matters before rendering a written decision thereon (by recommendation of an Application for Payment or otherwise), ENGINEER's written decisions thereon will be final and binding upon DISTRICT and CONTRACTOR, unless, within ten days after the date of any such decision, CONTRACTOR delivers to ENGINEER written notice of intention to appeal from such a decision.

Decisions on Disputes:

9.11 ENGINEER will be the initial interpreter of the requirements of the Contract Documents and judge of the acceptability of the Work thereunder. Claims, disputes and other matters relating to the acceptability of the Work or the interpretation of the requirements of the Contract Documents pertaining to the performance and furnishing of the Work and claims under Articles 11 and 12 in respect of changes in the Contract Price or Contract Time will be referred initially to ENGINEER in writing with a request for a formal decision in accordance with this paragraph, which ENGINEER will render in writing within a reasonable time. Written

Section IV - General Conditions

notice of each such claim, dispute and other matter will be delivered by the claimant to ENGINEER and the other party to the Agreement promptly (but in no event later than thirty days) after the occurrence of the event giving rise thereto, and written supporting data will be submitted to ENGINEER and the other party within sixty days after such occurrence unless ENGINEER allows an additional period of time to ascertain more accurate data in support of the claim.

9.12 The rendering of a decision by ENGINEER pursuant to paragraphs 9.10 and 9.11 with respect to any such claim, dispute or other matter (except any which have been waived by the making or acceptance of final payment as provided in paragraph 14.16) will be a condition precedent to any exercise by DISTRICT or CONTRACTOR of such rights or remedies as either may otherwise have under the Contract Documents or by Laws or Regulations in respect of any such claim, dispute or other matter.

Limitations on ENGINEER's Responsibilities:

9.13 Neither ENGINEER's authority to act under this Article 9 or elsewhere in the Contract Documents nor any decision made by ENGINEER in good faith either to exercise or not exercise such authority shall give rise to any duty or responsibility of ENGINEER to CONTRACTOR, any Subcontractor, any Supplier, or any other person or organization performing any of the Work, or to any surety for any of them.

9.14 Whenever in the Contract documents the terms "as ordered", "as directed", "as required", "as allowed", "as approved" or terms of like effect or import are used, or the adjectives "reasonable", "suitable", "acceptable", "proper", or "satisfactory" or adjectives of like effect or import are used to describe a requirement, direction, review or judgment of ENGINEER as to the Work, it is intended that such requirement, direction, review or judgment will be solely to evaluate the Work for compliance with the Contract Documents, (unless there is a specific statement indicating otherwise). The use of any such term or adjective shall not be effective to assign to ENGINEER any duty or authority to supervise or direct the furnishing or performance of the Work or any duty or authority to undertake responsibility contrary to the provisions of paragraph 9.15 or 9.16.

9.15 ENGINEER will not be responsible for CONTRACTOR's means, methods, techniques, sequences or procedures of construction or the safety precautions and programs incident thereto, and ENGINEER will not be responsible for CONTRACTOR's failure to perform or furnish the Work in accordance with the Contract Documents.

9.16 ENGINEER will not be responsible for the acts or omissions of CONTRACTOR or of any Subcontractor, any Supplier, or of any other person or organization performing or furnishing any of the Work.

ARTICLE 10--CHANGES IN THE WORK

10.1 Without invalidating the Agreement and without notice to any surety, DISTRICT may, at any time or from time to time, order additions, deletions or revisions in the Work; these will be authorized by a Written Amendment, A Change Order, or a Work Directive Change. Upon receipt of any such document, CONTRACTOR shall promptly proceed with the Work involved which will be performed under the applicable conditions of the Contract Documents, except as otherwise specifically provided.

10.2 If DISTRICT and CONTRACTOR are unable to agree as to the extent, if any, of an increase or decrease in the Contract Price or an extension or shortening of the Contract Time that should be allowed as result of a Work Directive change, a claim may be made therefor as provided in Article 11 or Article 12.

10.3 CONTRACTOR shall not be entitled to an increase in the Contract Price or an extension of the

Section IV - General Conditions

Contract Time with respect to any Work performed that is not required by the Contract Documents as amended, modified and supplemented as provided in paragraphs 3.4 and 3.5, except in the case of an emergency as provided in paragraph 6.22 and except in the case of uncovering Work as provided in paragraph 13.9.

10.4 DISTRICT and CONTRACTOR shall execute appropriate Change Orders (or Written Amendments) covering:

10.4.1 changes in the Work which are ordered by DISTRICT pursuant to paragraph 10.1, are required because of acceptance of "defective" Work under paragraph 13.13 or correcting "defective" Work under paragraph 13.14, or are agreed to by the parties;

10.4.2 changes in the Contract Price or Contract Time which are agreed to by the parties; and

10.4.3 changes in the Contract Price or Contract Time which embody the substance of any written decision rendered by ENGINEER pursuant to paragraph 9.11; provided that, in lieu of executing any such Change Order, an appeal may be taken from any such decision in accordance with the provisions of the Contract Documents and applicable Laws and Regulations; but during any such appeal, CONTRACTOR shall carry on the Work and adhere to the progress schedule as provided in paragraph 6.29.

10.5 If notice of any change affecting the general scope of the Work or the provisions of the Contract Documents (including, but not limited to, Contract Price or Contract Time) is required by the provisions of any Bond to be given to a surety, the giving of any such notice will be CONTRACTOR'S responsibility, and the amount of each applicable Bond will be adjusted accordingly.

ARTICLE 11--CHANGE OF CONTRACT PRICE

11.1 The Contract Price constitutes the total compensation (subject to authorized adjustments) payable to CONTRACTOR for performing the Work. All duties, responsibilities and obligations assigned to or undertaken by CONTRACTOR shall be at his expense without change in the Contract price.

11.2 The Contract Price may only be changed by a Change Order or by a Written Amendment. Any claim for an increase or decrease in the Contract Price shall be based on written notice delivered by the party making the claim to the other party and to ENGINEER promptly (but in no event later than thirty days) after the occurrence of the event giving rise to the claim and stating the general nature of the claim. Notice of the amount of the claim with supporting data shall be delivered within sixty days after such occurrence (unless ENGINEER allows an additional period of time to ascertain more accurate data in support of the claim) and shall be accompanied by claimant's written statement that the amount claimed covers all known amounts (direct, indirect and consequential) to which the claimant is entitled as a result of the occurrence of said event. All claims for adjustment in the Contract Price shall be determined by ENGINEER in accordance with paragraph 9.11. No claim for an adjustment in the Contract Price will be valid if not submitted in accordance with this paragraph.

11.3 The value of any Work covered by a Change Order or of any claim for an increase or decrease in the Contract Price shall be determined in one of the following ways:

11.3.1 Where the Work involved is covered by unit prices contained in the Contract Documents, by application of unit prices to the quantities of the items involved (subject to the provisions of paragraphs 11.8.1 through 11.8.3, inclusive).

Section IV - General Conditions

11.3.2 By mutual acceptance of a lump sum (which may include an allowance for overhead and profit not necessarily in accordance with paragraph 11.5.2.1).

11.3.3 On the basis of the Cost of the Work (determined as provided in paragraph 11.4) plus a CONTRACTOR's Fee for overhead and profit (determined as provided in paragraphs 11.5 and 11.6).

Cost of the Work:

11.4 The term Cost of the Work means the sum of all costs necessarily incurred and paid by CONTRACTOR in the proper performance of the Work. Except as otherwise may be agreed to in writing by DISTRICT, such costs shall be in amounts no higher than those prevailing in the locality of the Project, shall include only the following items:

11.4.1 Payroll costs for employees in the direct employ of CONTRACTOR in the performance of the Work under schedules of job classifications agreed upon by DISTRICT and CONTRACTOR. Payroll costs for employees not employed full time on the Work shall be apportioned on the basis of their time spent on the Work. Payroll costs shall include, but not be limited to, salaries and wages plus the cost of fringe benefits which shall include social security contributions, unemployment, excise and payroll taxes, workers' or workmen's compensation, health and retirement benefits, bonuses, sick leave, vacation and holiday pay applicable thereto. Employees shall include superintendents and foremen at the site. The expenses of performing Work after regular working hours, on Saturday, Sunday or legal holidays, shall be included in the above to the extent authorized by DISTRICT.

11.4.2 Cost of all materials and equipment furnished and incorporated in the Work, including costs of transportation and storage thereof, and Suppliers field services required in connection therewith. All cash discounts shall accrue to CONTRACTOR unless DISTRICT deposits funds with CONTRACTOR with which to make payments, in which case the cash discounts shall accrue to DISTRICT. All trade discounts, rebates and refunds and all returns from sale of surplus materials and equipment shall accrue to DISTRICT, and CONTRACTOR shall make provisions so that they may be obtained.

11.4.3 Payments made by CONTRACTOR to the Subcontractors for Work performed by Subcontractors. If required by DISTRICT, CONTRACTOR shall obtain competitive bids from Subcontractors acceptable to CONTRACTOR and shall deliver such bids to DISTRICT who will then determine, with the advice of ENGINEER, which bids will be accepted. If a subcontract provides that the Subcontractor is to be paid on the basis of Cost of the Work Plus a Fee, the Subcontractor's Cost of the Work shall be determined in the same manner as CONTRACTOR's Cost of the Work. All subcontracts shall be subject to the other provisions of the Contract Documents insofar as applicable.

11.4.4 Costs of special consultants (including but not limited to engineers, architects, testing laboratories, surveyors, attorneys and accountants) employed for services specifically related to the Work.

11.4.5 Supplemental costs including the following:

11.4.5.1 The proportion of necessary transportation, travel and subsistence expenses of CONTRACTOR's employees incurred in discharge of duties connected with the Work.

11.4.5.2 Cost, including transportation and maintenance, of all materials, supplies, equipment, machinery, appliances, office and temporary facilities at the site and hand tools not owned by the workers, which are consumed in the performance of the Work, and cost less market value of such

Section IV - General Conditions

items used but not consumed which remain the property of CONTRACTOR.

11.4.5.3 Rentals of all construction equipment and machinery and the parts thereof whether rented from CONTRACTOR or others in accordance with rental agreements approved by DISTRICT with the advice of ENGINEER, and the costs of transportation, loading, unloading, installation, dismantling and removal thereof-- all in accordance with terms of said rental agreements. The rental of any such equipment, machinery or parts shall cease when the use thereof is no longer necessary for the Work.

11.4.5.4 Sales, consumer, use or similar taxes related to the Work, and for which CONTRACTOR is liable, imposed by Laws and Regulations.

11.4.5.5 Deposits lost for causes other than negligence of CONTRACTOR, any Subcontractor or anyone directly or indirectly employed by any of them or for whose acts any of them may be liable, and royalty payments and fees for permits and licenses.

11.4.5.6 Losses and damages (and related expenses), not compensated by insurance or otherwise, to the Work or otherwise sustained by CONTRACTOR in connection with the performance and furnishing of the Work, (except losses and damages within the deductible amounts of property insurance established by DISTRICT in accordance with paragraph 5.9) provided they have resulted from causes other than the negligence of CONTRACTOR, any Subcontractor, or anyone directly or indirectly employed by any of them or for whose acts any of them may be liable. Such losses shall include settlements made with the written consent and approval of DISTRICT. No such losses, damages and expenses shall be included in the Cost of the Work for the purpose of determining CONTRACTOR's Fee. If however, any such loss or damage requires reconstruction and CONTRACTOR is placed in charge thereof, CONTRACTOR shall be paid for services a fee proportionate to that stated in paragraph 11.5.2.

11.4.5.7 The cost of utilities, fuel and sanitary facilities at the site.

11.4.5.8 Minor expenses such as telegrams, long distance telephone calls, telephone service at the site, expressage and similar petty cash items in connection with the Work.

11.4.5.9 Cost of premiums for additional Bonds and insurance required because of changes in the Work and premiums for property insurance coverage within the limits of the deductible amounts are established by DISTRICT in accordance with paragraph 5.14

Contractor's Fee:

11.5 The CONTRACTOR's Fee allowed to CONTRACTOR for overhead and profit shall be determined as follows:

11.5.1 a mutually acceptable fixed fee; or if none can be agreed upon, fee will be determined according to procedure in the following paragraphs;

11.5.2 a fee based on the following percentages of the various portions of the Cost of the Work;

11.5.2.1 for costs incurred under paragraphs 11.4.1 and 11.4.2, the CONTRACTOR's Fee shall be fifteen percent;

Section IV - General Conditions

11.5.2.2 for costs incurred under paragraph 11.4.3, the CONTRACTOR's Fee shall be five percent; and if a subcontract is on the basis of Cost of the Work Plus a Fee, the maximum allowable to CONTRACTOR on account of overhead and profit of all Subcontractors shall be fifteen percent;

11.5.2.3 no fee shall be payable on the basis of costs itemized under paragraphs 11.4.4, and 11.4.5;

11.5.2.4 the amount of credit to be allowed by CONTRACTOR to DISTRICT for any such change which results in a net decrease in cost will be the amount of the actual net decrease plus a deduction in Contractor's Fee by an amount equal to ten percent of the net decrease; and

11.5.2.5 when both additions and credits are involved in any one change, the adjustment in CONTRACTOR's Fee shall be computed on the basis of the net change in accordance with paragraphs 11.5.2.1 through 11.5.2.4, inclusive.

11.6 Whenever the cost of any Work is to be determined pursuant to paragraph 11.4 or 11.5, CONTRACTOR will submit in form acceptable to ENGINEER an itemized cost breakdown together with supporting data.

Cash Allowances:

11.7 It is understood that CONTRACTOR has included in the Contract Price all allowances so named in the Contract Documents and shall cause the Work so covered to be done by such Subcontractors or Suppliers and for such sums within the limit of the allowances as may be acceptable to ENGINEER, CONTRACTOR agrees that:

11.7.1 The allowances include the cost to CONTRACTOR (less any applicable trade discounts) of materials and equipment required by the allowances to be delivered at the site, and all applicable taxes; and

11.7.2 CONTRACTOR's costs for unloading and handling on the site, labor, installation costs, overhead, profit and other expenses contemplated for the allowances have been included in the Contract Price and not in the allowances. No demand for additional payment on account of any thereof will be valid.

Prior to final payment, an appropriate Change Order will be issued as recommended by ENGINEER to reflect actual amounts due CONTRACTOR on account of Work covered by allowances, and the Contract Price shall be correspondingly adjusted.

Unit Price Work:

11.8.1 Where the Contract Documents provide that all or part of the Work is to be Unit Price Work, initially the Contract Price will be deemed to include for all Unit Price Work in an amount equal to the sum of the established unit prices for each separately identified item of Unit Price work times the estimated quantity of each item as indicated in the Agreement. The estimated quantities of items of Unit Price work are not guaranteed and are solely for the purpose of comparison of Bids and determining an initial Contract Price. Determinations of the actual quantities and classifications of Unit Price Work performed by CONTRACTOR will be made by ENGINEER in accordance with paragraph 9.10.

11.8.2 Each unit price will be deemed to include an amount considered by CONTRACTOR to be

Rev 6 10

Section IV - General Conditions

adequate to cover CONTRACTOR's overhead and profit for each separately identified item.

11.8.3 Where the quantity of any item of Unit Price Work performed by CONTRACTOR differs materially and significantly from the estimated quantity of such item indicated in the Agreement and there is no corresponding adjustment with respect to any other item of Work and if CONTRACTOR believes that CONTRACTOR has incurred additional expense as a result thereof, CONTRACTOR may make a claim for an increase in the Contract Price in accordance with Article 11 if the parties are unable to agree as to the amount of any such increase.

ARTICLE 12--CHANGE OF CONTRACT TIME

12.1 The Contract Time may only be changed by a Change Order or a Written Amendment. Any claim for an extension or shortening of the Contract time shall be based on written notice delivered by the party making the claim to the other party promptly (but in no event later than thirty days) after the occurrence of the event giving rise to the claim and stating the general nature of the claim. Notice of the extent of the claim with supporting data shall be delivered within sixty days after such occurrence (unless ENGINEER allows an additional period of time to ascertain more accurate data in support of the claim) and shall be accompanied by the claimant's written statement that the adjustment claimed is the entire adjustment to which the claimant has reason to believe it is entitled as a result of the occurrence of said event. All claims for adjustment in the Contract time shall be determined by ENGINEER in accordance with paragraph 9.11 No claim for an adjustment in the Contract Time will be valid if not submitted in accordance with the requirements of this paragraph..

12.2 The Contract Time will be extended in an amount equal to time lost due to delays beyond the control of CONTRACTOR if a claim is made therefore as provided in paragraph 12.1. Such delays shall include, but not be limited to, acts or neglect by DISTRICT or others performing additional work as contemplated by Article 7, or to fires, floods, labor disputes, epidemics, abnormal weather conditions or acts of God. Abnormal weather conditions will be determined based on daily and monthly data and departures from normal, as published by the National Climatic Data Center, Asheville, NC. Consideration will be given to localized weather events at the job site, and the time required to resume progress on the job.

12.3 All time limits stated in the Contract Documents are of the essence of the Agreement. The provisions of this Article 12 shall not exclude recovery for damages (including but not limited to fees and charges of engineers, architects, attorneys and other professionals and court and appeals costs) for delay by either party.

ARTICLE 13--WARRANTY AND GUARANTEE; TESTS AND INSPECTIONS; CORRECTION, REMOVAL OR ACCEPTANCE OF DEFECTIVE WORK

Warranty and Guarantee:

13.1 CONTRACTOR warrants and guarantees to DISTRICT that all Work will be in accordance with the Contract Documents and will not be "defective". Prompt notice of all defects shall be given to CONTRACTOR. All "defective" Work, whether or not in place, may be rejected, corrected or accepted as provided in this Article 13.

Access to Work:

13.2 ENGINEER and other representatives of DISTRICT, testing agencies and governmental agencies with jurisdictional interests will have access to the Work at reasonable times for their observation, inspection and testing. CONTRACTOR shall provide proper and safe conditions for such access.

Section IV - General Conditions

Tests and Inspections:

13.3 CONTRACTOR shall give ENGINEER timely notice of readiness of the Work for all required inspections, tests or approvals.

13.4 If Laws or Regulations of any public body having jurisdiction require any Work (or part thereof) to specifically be inspected, tested or approved, CONTRACTOR shall assume full responsibility therefor, pay all costs in connection therewith and furnish ENGINEER the required certificates of inspection, testing or approval. CONTRACTOR shall also be responsible for and shall pay all costs in connection with any inspection or testing required in connection with DISTRICT's acceptance of a Supplier of materials or equipment proposed to be incorporated in the Work, or of materials or equipment submitted for approval prior to CONTRACTOR's purchase thereof for incorporation in the Work. The cost of all inspections, tests and approvals in addition to the above which are required by the Contract Documents shall be paid by DISTRICT (unless otherwise specified).

13.5 All inspections, tests or approvals other than those required by Laws or Regulations of any public body having jurisdiction shall be performed by organizations acceptable to DISTRICT and CONTRACTOR (or by ENGINEER if so specified).

13.6 If any Work (including the work of others) that is to be inspected, tested or approved is covered without written concurrence of ENGINEER, it must, if requested by ENGINEER, be uncovered for observation. Such uncovering shall be at CONTRACTOR's expense unless CONTRACTOR had given ENGINEER timely notice of CONTRACTOR's intention to cover the same and ENGINEER has not acted with reasonable promptness in response to such notice.

13.7 Neither observations by ENGINEER nor inspections, tests or approvals by others shall relieve CONTRACTOR from CONTRACTOR's obligations to perform the Work in accordance with the Contract Documents.

Uncovering Work:

13.8 If any Work is covered contrary to the written request of ENGINEER, it must, if requested by ENGINEER, be uncovered for ENGINEER's observation and replaced at CONTRACTOR's expense.

13.9 If ENGINEER considers it necessary or advisable that covered Work be observed by ENGINEER or inspected or tested by others, CONTRACTOR, at ENGINEER's request, shall uncover, expose or otherwise make available for observation, inspection or testing as ENGINEER may require, that portion of the Work in question, furnishing all necessary labor, material and equipment. If it is found that such Work is "defective", CONTRACTOR shall bear all direct, indirect and consequential costs of such uncovering, exposure, observation, inspection and testing and of satisfactory reconstruction, (including but not limited to fees and charges of engineers, architects, attorneys and other professionals), and DISTRICT shall be entitled to an appropriate decrease in the Contract Price; and if the parties are unable to agree as to the amount thereof, may make a claim therefor as provided in Article 11. If, however, such Work is not found to be "defective", CONTRACTOR shall be allowed an increase in the Contract Price or an extension of the Contract Time, or both, directly attributable to such uncovering, exposure, observation, inspection, testing and reconstruction; and, if the parties are unable to agree as to the amount or extent thereof, CONTRACTOR may make a claim therefor as provided in Article 11 and 12.

DISTRICT May Stop the Work:

Section IV - General Conditions

13.10 If the Work is "defective", or CONTRACTOR fails to supply sufficient skilled workers or suitable materials or equipment, or fails to furnish or perform the Work in such a way that the completed Work will conform to the Contract Documents, DISTRICT may order CONTRACTOR to stop the Work, or any portion thereof, until the cause for such order has been eliminated; however, this right of DISTRICT to stop the Work shall not give rise to any duty on the part of DISTRICT to exercise this right for the benefit of CONTRACTOR or any other party.

Correction or Removal of Defective Work:

13.11 If required by ENGINEER, CONTRACTOR shall promptly, as directed, either correct all "defective" Work, whether or not fabricated, installed or completed, or if the Work has been rejected by ENGINEER, remove it from the site and replace it with "non-defective" Work. CONTRACTOR shall bear all direct, indirect and consequential costs of such correction or removal (including but not limited to fees and charges of engineers, architects, attorneys and other professionals) made necessary thereby.

One Year Correction Period:

13.12 If within one year after the date of Substantial Completion or such longer period of time as may be prescribed by Laws or Regulations or by the terms of any applicable special guarantee required by the Contract Documents or by any specific provisions of the Contract Documents, any Work is found to be "defective", CONTRACTOR shall promptly, without cost to DISTRICT and in accordance with DISTRICT's written instructions, either correct such "defective" Work, or, if it has been rejected by DISTRICT, remove it from the site and replace it with "non-defective" Work. If CONTRACTOR does not promptly comply with the terms of such instructions, or in an emergency where delay would cause serious risk of loss or damage, DISTRICT may have the "defective" Work corrected or the rejected Work removed and replaced, and all direct, indirect and consequential costs of such removal and replacement (including but not limited to fees and charges of engineers, architects, attorneys and other professionals) will be paid by CONTRACTOR. In special circumstances where a particular item of equipment is placed in continuous service before Substantial Completion of all the Work, the correction period for that item may start to run from an earlier date if so provided in the Specifications or by Written Amendment.

Acceptance of Defective Work:

13.13 If, instead of requiring correction or removal and replacement of "defective" Work, DISTRICT (and, prior to ENGINEER's recommendation of final payment, also ENGINEER) prefers to accept it, DISTRICT may do so. CONTRACTOR shall bear all direct, indirect and consequential costs attributable to DISTRICT's evaluation of and determination to accept such "defective" Work (such costs to be approved by ENGINEER as to reasonableness and to include but not be limited to fees and charges of engineers, architects, attorneys and other professionals). If any such acceptance occurs prior to ENGINEER's recommendation of final payment, a Change Order will be issued incorporating the necessary revisions in the Contract Documents with respect to the Work; and DISTRICT shall be entitled to an appropriate decrease in the Contract Price, and, if the parties are unable to agree as to the amount thereof, DISTRICT may make a claim therefor as provided in Article 11. If the acceptance occurs after such recommendation, an appropriate amount will be paid by CONTRACTOR to DISTRICT.

DISTRICT May Correct Defective Work:

13.14 If CONTRACTOR fails within a reasonable time after written notice of ENGINEER to proceed to correct "defective" Work or to remove and replace rejected Work as required by ENGINEER in accordance

Section IV - General Conditions

with paragraph 13.11, or if CONTRACTOR fails to perform the Work in accordance with the Contract documents, or if CONTRACTOR fails to comply with any other provision of the Contract Documents, DISTRICT may, after seven days written notice to CONTRACTOR, correct and remedy any such deficiency. In exercising the rights and remedies under this paragraph DISTRICT shall proceed expeditiously. To the extent necessary to complete corrective and remedial action, DISTRICT may exclude CONTRACTOR from all or part of the site, take possession of all or part of the Work, and suspend CONTRACTOR's services related thereto, take possession of CONTRACTOR's tools, appliances, construction equipment and machinery at the site and incorporate in the Work all materials and equipment stored at the site or for which DISTRICT has paid CONTRACTOR but which are stored elsewhere. CONTRACTOR shall allow DISTRICT, DISTRICT's representatives, agents and employees such access to the site as may be necessary to enable DISTRICT to exercise the rights and remedies under this paragraph. All direct, indirect and consequential costs of DISTRICT in exercising such rights and remedies will be charged against CONTRACTOR in an amount approved as to reasonableness by ENGINEER, and a change Order will be issued incorporating the necessary revisions in the Contract Documents with respect to the Work; and DISTRICT shall be entitled to an appropriate decrease in the Contract Price, and, if the parties are unable to agree as to the amount thereof, DISTRICT may make a claim therefor as provided in Article 11. Such direct, indirect and consequential costs will include but not be limited to fees and charges of engineers, architects, attorneys and other professionals, all court and appeals costs and all costs of repair and replacement of work of others destroyed or damaged by correction, removal or replacement of CONTRACTOR's "defective" Work. CONTRACTOR shall not be allowed an extension of the Contract Time because of any delay in performance of the Work attributable to the exercise by DISTRICT of DISTRICT's rights and remedies hereunder.

ARTICLE 14--PAYMENTS TO CONTRACTOR AND COMPLETION

Schedule of Values:

14.1 The schedule of values established as provided in paragraph 2.11 will serve as the basis for progress payments and will be incorporated into a form of Application for Payment acceptable to ENGINEER. Progress payments on account of Unit Price Work will be based on the number of units completed in accordance with these contract documents.

Application for Progress Payment:

14.2 At least twenty days before each progress payment is scheduled (but not more often than once a month), CONTRACTOR shall submit to ENGINEER for review an Application for Payment filled out and signed by CONTRACTOR covering the Work completed as of the date of the Application and accompanied by such supporting documentation as is required by the Contract Documents. If payment is requested on the basis of materials and equipment not incorporated in the Work but delivered and suitably stored at the site or at another location agreed to in writing, the Application for Payment shall also be accompanied by a bill of sale, invoice or other documentation warranting that DISTRICT has received the materials and equipment free and clear of all liens, charges, security interests and encumbrances (which are hereinafter in these General Conditions referred to as "Liens") and evidence that the materials and equipment are covered by appropriate property insurance and other arrangements to protect DISTRICT's interest therein, all of which will be satisfactory to DISTRICT. The amount of retainage with respect to progress payments will be as stipulated in the Agreement.

Contractor's Warranty of Title:

14.3 CONTRACTOR warrants and guarantees that title to all Work, materials and equipment covered by any Application for Payment, whether incorporated in the Project or not, will pass to DISTRICT no later than

Section IV - General Conditions

the time of payment, free and clear of all Liens.

Review of Applications for Progress Payment:

14.4 ENGINEER will, within ten days after receipt of each application for Payment, either indicate in writing a recommendation of payment and present the Application to DISTRICT, or return the Application to CONTRACTOR indicating in writing ENGINEER's reasons for refusing to recommend payment. In the latter case, CONTRACTOR may make the necessary corrections and re-submit the Application. Ten days after presentation of the Application for Payment with ENGINEER's recommendation, the amount recommended will (subject to the provisions of the last sentence of paragraph 14.7) become due and when due will be paid by DISTRICT to CONTRACTOR.

14.5 ENGINEER'S recommendation of any payment requested in an Application for Payment will constitute a representation by ENGINEER, based on ENGINEER's on-site observations of the Work in progress as an experienced and qualified design professional and on ENGINEER's review of the application for payment and the accompanying data and schedules that the work has progressed to the point indicated that to the best of ENGINEER's knowledge, information and belief, the quality of the Work is in accordance with the Contract Documents (subject to an evaluation of the Work as a functioning whole prior to or upon Substantial Completion, to the results of any subsequent tests called for in the Contract Documents, to a final determination of quantities and classifications for Unit Price Work under paragraph 9.10, and to any other qualifications stated in the recommendation); and that CONTRACTOR is entitled to payment of the amount recommended. However, by recommending any such payment ENGINEER will not thereby be deemed to have represented that exhaustive or continuous on-site inspections have been made to check the quality or the quantity of the Work beyond the responsibilities specifically assigned to ENGINEER in the Contract Documents or that there may not be other matters or issues between the parties that might entitle CONTRACTOR to be paid additionally by DISTRICT or DISTRICT to withhold payment to CONTRACTOR.

14.6 ENGINEER's recommendation of final payment will constitute an additional representation by ENGINEER that the conditions precedent to CONTRACTOR's being entitled to final payment as set forth in paragraph 14.13 have been fulfilled.

14.7 ENGINEER may refuse to recommend the whole or any part of any payment if, in ENGINEER's opinion, it would be incorrect to make such recommendation to DISTRICT. ENGINEER may also refuse to recommend any such payment, or, because of subsequently discovered evidence or the results of subsequent inspections or tests, nullify any such payment previously recommended, to such extent as may be necessary in ENGINEER's opinion to protect DISTRICT from loss because:

14.7.1 the Work is "defective", or completed Work has been damaged requiring correction or replacement;

14.7.2 the Contract Price has been reduced by Written Amendment or Change Order;

14.7.3 DISTRICT has been required to correct "defective" Work or complete Work in accordance with paragraph 13.14; or

14.7.4 of ENGINEER's actual knowledge of the occurrence of any of the events enumerated in paragraphs 15.2.1 through 15.2.9 inclusive.

14.8 DISTRICT may refuse to make payment of the full amount recommended by ENGINEER because

Section IV - General Conditions

claims have been made against DISTRICT on account of CONTRACTOR's performance or furnishing of the Work or Liens have been filed in connection with the Work or there are other items entitling DISTRICT to a set-off against the amount recommended, but DISTRICT must give CONTRACTOR immediate written notice stating the reasons for such action.

Substantial Completion:

14.9 When CONTRACTOR considers the entire Work ready for its intended use, CONTRACTOR shall notify ENGINEER in writing that the entire Work is substantially complete (except for items specifically listed by CONTRACTOR as incomplete) and request that ENGINEER issue a certificate of Substantial Completion. Within a reasonable time thereafter, CONTRACTOR and ENGINEER shall make an inspection of the Work to determine the status of completion. If ENGINEER does not consider the Work substantially complete, ENGINEER will notify CONTRACTOR in writing giving the reasons therefor. If ENGINEER considers the Work substantially complete, ENGINEER will prepare a tentative certificate of Substantial Completion which shall fix the date of Substantial Completion. There shall be attached to the certificate a tentative list of items to be completed or corrected before final payment. If, after completion of items on tentative list ENGINEER considers the Work substantially complete, ENGINEER will within fourteen days execute and deliver to CONTRACTOR a definitive certificate of Substantial Completion (with a revised tentative list of items to be completed or corrected) reflecting such changes from the tentative certificate as the ENGINEER believes justified. At the time of delivery of the tentative certificate of Substantial Completion, ENGINEER will deliver to CONTRACTOR a written recommendation as to division of responsibilities pending final payment by DISTRICT to CONTRACTOR with respect to security, operation, safety, maintenance, heat, utilities, insurance, warranties, and any other incomplete items of the Work. Unless CONTRACTOR disagrees otherwise in writing and informs ENGINEER prior to ENGINEER'S issuing the definitive certificate of Substantial Completion, ENGINEER's aforesaid recommendation will be binding on CONTRACTOR until final payment.

14.10 DISTRICT shall have the right to exclude CONTRACTOR from the Work after the date of Substantial Completion, but DISTRICT shall allow CONTRACTOR reasonable access to complete or correct items on the tentative list.

Partial Utilization:

14.11 Use by DISTRICT of any finished part of the Work, which has specifically been identified in the Contract Documents, or which DISTRICT, ENGINEER and CONTRACTOR agree constitutes a separately functioning and usable part of the Work that can be used by DISTRICT without significant interference with CONTRACTOR's performance of the remainder of the Work, may be accomplished prior to Substantial Completion of all the Work subject to the following:

14.11.1 DISTRICT may at any time request CONTRACTOR in writing to permit DISTRICT to use any such part of the Work which DISTRICT believes to be ready for its intended use and substantially complete. If CONTRACTOR agrees, CONTRACTOR will certify to DISTRICT and ENGINEER that said part of the Work is substantially complete and request ENGINEER to issue a certificate of Substantial Completion for that part of the Work. CONTRACTOR at any time may notify DISTRICT and ENGINEER in writing that CONTRACTOR considers any such part of the Work ready for its intended use and substantially complete and request ENGINEER to issue a certificate of Substantial Completion for that part of the Work. Within a reasonable time after either such request, CONTRACTOR and ENGINEER shall make an inspection of that part of the Work to determine its status of completion. If ENGINEER does not consider that part of the Work to be substantially complete, ENGINEER will notify CONTRACTOR in writing giving the reasons therefor. If

Section IV - General Conditions

ENGINEER considers that part of the Work to be substantially complete, the provisions of paragraphs 14.9 and 14.10 will apply with respect to certification of Substantial Completion of that part of the Work and the division of responsibility in respect thereof and access thereto.

14.11.2 DISTRICT may at any time request CONTRACTOR in writing to permit DISTRICT to take over operation of any such part of the Work although it is not substantially complete, and within a reasonable time thereafter CONTRACTOR and ENGINEER shall make an inspection of that part of the Work to determine its status of completion and will prepare a list of the items remaining to be completed or corrected thereon before final payment. If CONTRACTOR does not object in writing to ENGINEER that such part of the Work is not ready for separate operation by DISTRICT, ENGINEER will finalize the list of items to be completed or corrected and will deliver such list to CONTRACTOR together with a written recommendation as to the division of responsibilities pending final payment between DISTRICT and CONTRACTOR with respect to security, operation, safety, maintenance, utilities, insurance, warranties and guarantees for that part of the Work which will become binding upon CONTRACTOR at the time when DISTRICT takes over such operation. During such operation and prior to Substantial Completion of such part of the Work, DISTRICT shall allow CONTRACTOR reasonable access to complete or correct items on said list and to complete other related Work.

14.11.3 No occupancy or separate operation of part of the work will be accomplished prior to compliance with the requirements of paragraph 5.12 in respect of property insurance.

Final Inspection:

14.12 Upon written notice from CONTRACTOR that the entire Work or an agreed portion thereof is complete, ENGINEER will make a final inspection with CONTRACTOR and will notify CONTRACTOR in writing of all particulars in which this inspection reveals that the Work is incomplete or "defective" (punch list). CONTRACTOR shall immediately take such measures as are necessary to remedy such deficiencies.

Final Application for Payment:

14.13 After CONTRACTOR has completed all such corrections to the satisfaction of ENGINEER and delivered all maintenance and operating instructions, schedules, guarantees, Bonds, certificates of inspection, marked-up record documents (as provided in paragraph 6.19) and other documents--all as required by the Contract Documents, and after ENGINEER has indicated that the Work is acceptable (subject to the provisions of paragraph 14.17), CONTRACTOR may make application for final payment following the procedure for progress payments. The final Application for Payment shall be accompanied by all documentation called for in the Contract Documents, together with complete and legally effective releases or waivers (satisfactory to DISTRICT) of all Liens arising out of or filed in connection with the Work. In lieu thereof and as approved by DISTRICT, CONTRACTOR may furnish receipts or releases in full; an affidavit of CONTRACTOR that the releases and receipts include all labor, services, material and equipment for which a Lien could be filed, and that all payrolls, material and equipment bills, and other indebtedness connected with the Work for which DISTRICT or DISTRICT's property might in any way be responsible, have been paid or otherwise satisfied; and consent of the surety, if any, to final payment. If any Subcontractor or Supplier fails to furnish a release or receipt in full, CONTRACTOR may furnish a Bond or other collateral satisfactory to DISTRICT to indemnify DISTRICT against any Lien.

Final Payment and Acceptance:

14.14 If, on the basis of ENGINEER's observation of the Work during construction and final inspection, and

Section IV - General Conditions

ENGINEER's review of the final Application for Payment and accompanying documentation--all as required by the Contract Documents, ENGINEER is satisfied that the Work has been completed and CONTRACTOR's other obligations under the Contract Documents have been fulfilled, ENGINEER will, within ten days after receipt of the final Application for Payment, indicate in writing ENGINEER's recommendation of payment Thereupon, ENGINEER will give written notice to CONTRACTOR that the Work is acceptable subject to the provisions of paragraph 14.17. Otherwise, ENGINEER will return the Application to CONTRACTOR, indicating in writing the reasons for refusing to recommend final payment, in which case CONTRACTOR shall make the necessary corrections and re-submit the Application. Thirty days after presentation to DISTRICT of the Application and accompanying documentation, in appropriate form and substance, and with ENGINEER's recommendation and notice of acceptability, the amount recommended by ENGINEER will become due and will be paid by DISTRICT to CONTRACTOR.

14.15 If, through no fault of CONTRACTOR, final completion of the Work is significantly delayed and if ENGINEER so confirms, DISTRICT shall, upon receipt of CONTRACTOR's final Application for Payment and recommendation of ENGINEER, and without terminating the Agreement, make payment of the balance due for that portion of the Work fully completed and accepted. If the remaining balance to be held by DISTRICT for Work not fully completed or corrected is less than the retainage stipulated in the Agreement, and if Bonds have been furnished as required in paragraph 5.1, the written consent of the surety to the payment of the balance due for that portion of the Work fully completed and accepted shall be submitted by CONTRACTOR to ENGINEER with the Application for such payment. Such payment shall be made under the terms and conditions governing final payment, except that it shall not constitute a waiver of claims.

Contractor's Continuing Obligation:

14.16 CONTRACTOR's obligation to perform and complete the Work in accordance with the Contract Documents shall be absolute. Neither recommendation of any progress or final payment by ENGINEER, nor the issuance of a certificate of Substantial Completion, nor any payment by DISTRICT to CONTRACTOR under the Contract Documents, nor any use or occupancy of the Work or any part thereof by DISTRICT, nor any act of acceptance by DISTRICT, nor any failure to do so, nor any review and approval of a shop Drawing or sample submission, nor the issuance of a notice of acceptability by ENGINEER pursuant to paragraph 14.13, nor any correction of "defective" WORK by DISTRICT will constitute an acceptance of Work not in accordance with the Contract Documents or a release of CONTRACTOR's obligation to perform the Work in accordance with the Contract Documents (except as provided in paragraph 14.17).

Waiver of Claims:

14.17 The making and acceptance of final payment will constitute:

14.17.1 a waiver of all claims by DISTRICT against CONTRACTOR, except claims arising from unsettled Liens, from "defective" Work appearing after final inspection pursuant to paragraph 14.12 or from failure to comply with the Contract Documents or the terms of any special guarantees specified therein; however, it will not constitute a waiver by DISTRICT of any rights in respect of CONTRACTOR's continuing obligations under the Contract Documents; and

14.17.2 a waiver of all claims by CONTRACTOR against DISTRICT other than those previously made in writing and still unsettled.

ARTICLE 15--SUSPENSION OF WORK AND TERMINATION

DISTRICT May Suspend Work:

Section IV - General Conditions

15.1 DISTRICT may, at any time and without cause, suspend the Work or any portion thereof for a period of not more than ninety days by notice in writing to CONTRACTOR which will fix the date on which Work will be resumed. CONTRACTOR shall resume the Work on the date so fixed. CONTRACTOR shall be allowed an increase in the Contract Price or an extension of the Contract Time, or both, directly attributable to any suspension if CONTRACTOR makes an approved claim therefor as provided in Articles 11 and 12.

DISTRICT May Terminate:

15.2 Upon the occurrence of any one or more of the following events:

15.2.1 if CONTRACTOR commences a voluntary case under any chapter of the Bankruptcy Code (Title 11, United States Code), as now or hereafter in effect, or if CONTRACTOR takes any equivalent or similar action by filing a petition or otherwise under any other federal or state law in effect at such time relating to the bankruptcy or insolvency;

now 15.2.2 if a petition is filed against CONTRACTOR under any chapter of the Bankruptcy Code as now or hereafter in effect at the time of filing, or if a petition is filed seeking any such equivalent or similar relief against CONTRACTOR under any other federal or state law in effect at the time relating to bankruptcy or insolvency;

15.2.3 if CONTRACTOR makes a general assignment for the benefit of creditors;

15.2.4 if a trustee, receiver, custodian or agent of CONTRACTOR is appointed under applicable law or under contract, whose appointment or authority to take charge of property of CONTRACTOR is for the purpose of enforcing a Lien against such property or for the purpose of general administration of such property for the benefit of CONTRACTOR's creditors;

due; 15.2.5 if CONTRACTOR admits in writing an inability to pay its debts generally as they become

15.2.6 if CONTRACTOR persistently fails to perform the Work in accordance with the Contract Documents (including, but not limited to, failure to supply sufficient skilled workers or suitable materials or equipment or failure to adhere to the progress schedule established under paragraph 2.11 as revised from time to time);

15.2.7 if CONTRACTOR disregards Laws or Regulations of any public body having jurisdiction;

15.2.8 if CONTRACTOR disregards the authority of ENGINEER; or

15.2.9 if CONTRACTOR otherwise violates in any substantial way any provisions of the Contract Documents;

DISTRICT may, after giving CONTRACTOR (and the surety, if there be one) seven days written notice and to the extent permitted by Laws and Regulations, terminate the services of CONTRACTOR, exclude CONTRACTOR from the site and take possession of the Work, incorporate in the Work all materials and equipment stored at the site or for which DISTRICT has paid CONTRACTOR but which are stored elsewhere, and finish the Work as DISTRICT may deem expedient. In such case CONTRACTOR shall not be entitled to receive any further payment until the Work is finished. If the unpaid balance of the Contract Price exceeds the direct, indirect and consequential costs of completing the Work (including but not limited to fees and charges

Section IV - General Conditions

of engineers, architects, attorneys and other professionals and court and appeals costs) such excess will be paid to CONTRACTOR. If such costs exceed such unpaid balance, CONTRACTOR shall pay the difference to DISTRICT. Such costs incurred by DISTRICT will be approved as to reasonableness by ENGINEER and incorporated in a Change Order, but when exercising any rights or remedies under this paragraph DISTRICT shall not be required to obtain the lowest price for the Work performed.

15.3 Where CONTRACTOR's services have been so terminated by DISTRICT, the termination will not affect any rights or remedies of DISTRICT against CONTRACTOR then existing or which may thereafter accrue. Any retention or payment of monies due CONTRACTOR by DISTRICT will not release CONTRACTOR from liability.

15.4 Upon seven days written notice to CONTRACTOR, DISTRICT may, without cause and without prejudice to any other right or remedy, elect to abandon the Work and terminate the Agreement. In such case, CONTRACTOR shall be paid for all Work executed and any expense sustained plus reasonable termination expenses, which will include, but not be limited to direct, indirect and consequential costs (including, but not limited to fees and charges of engineers, architects, attorneys and other professionals and court and appeals costs).

CONTRACTOR May Stop Work or Terminate:

15.5 If, through no act or fault of CONTRACTOR, the Work is suspended for a period of more than ninety days by DISTRICT or under an order of court or other public authority, or ENGINEER fails to act on any Application for Payment, without good cause, within thirty days after it is submitted, or DISTRICT fails for thirty days to pay CONTRACTOR any sum finally determined to be due, then CONTRACTOR may, upon seven days written notice to DISTRICT and ENGINEER, terminate the Agreement and recover from DISTRICT payment for all Work executed and any expense sustained plus reasonable termination expenses. In addition and in lieu of terminating the Agreement, if ENGINEER has failed to act on an Application for Payment or DISTRICT has failed to make any payment as aforesaid, CONTRACTOR may upon seven days written notice to DISTRICT and ENGINEER stop the Work until payment of all amounts then due. The provisions of this paragraph shall not relieve CONTRACTOR of the obligations under paragraph 6.29 to carry on the Work in accordance with the progress schedule and without delay during disputes and disagreements with DISTRICT.

ARTICLE 16 - CONFLICT/APPEALS RESOLUTION

16.1 Claims, disputes and other matters in question between DISTRICT and CONTRACTOR arising out of or relating to the work may be decided by arbitration in accordance with the Construction Industry Arbitration Rules of the American Arbitration Association then in effect, provided that both parties must agree, in writing, to arbitration. No request for arbitration shall be made when a matter has been referred to the ENGINEER pursuant to Paragraph 9.11 until the earlier of - the date on which the ENGINEER renders his opinion or the tenth (10) day after the parties have presented their evidence to the ENGINEER and no written decision has been rendered by that time, or by mutual agreement of the parties.

16.2 Notice of a request for arbitration shall be filed, in writing, signed by both parties with the American Arbitration Association. A copy shall be served on the DISTRICT and CONTRACTOR. Said request shall be made within a reasonable time after the claim, dispute or other matter in question has arisen. In no event shall the request for arbitration be made after the date and the applicable statute of limitations would bar institution of legal or equitable proceeding based on such claims, dispute or other matter in question.

16.3 The award rendered by an arbitrator shall be final, and judgment may be entered upon it in accordance

Section IV - General Conditions

with applicable law in any court having jurisdiction.

16.4 Unless otherwise agreed in writing, the CONTRACTOR shall carry on the work and maintain progress during any arbitration proceedings, and the DISTRICT shall continue to make payments in accordance with the contract documents to the CONTRACTOR. No arbitration arising out of or relating to the work shall include, by consolidation or joinder on any other manner, an additional person not a party to the contract between the DISTRICT and the CONTRACTOR except by written consent of that person containing specific reference to the work and signed by the DISTRICT, the CONTRACTOR and the persons sought to be joined. Consent to arbitration involving an additional person or persons shall not constitute consent to arbitration of a dispute not described or with a person not named therein. This provision shall be specifically enforced by any court of competent jurisdiction.

16.5 Nothing herein shall prevent the DISTRICT or the CONTRACTOR from proceeding with litigation, provided, however, any litigation hereunder shall be brought in the General Court of Justice in the 28th Judicial District of North Carolina.

ARTICLE 17--MISCELLANEOUS

Giving Notice:

17.1 Whenever any provision of the Contract Documents requires the giving of written notice, it will be deemed to have been validly given if delivered in person to the individual or to a member of the firm or to an officer of the corporation for whom it is intended, or if delivered at or sent by registered or certified mail, postage prepaid, to the last business address known to the giver of the notice.

Computation of Time:

17.2.1 When any period of time is referred to in the Contract Documents by days, it will be computed to exclude the first and include the last day of such period. If the last day of any such period falls on a Saturday or Sunday or on a day made a legal holiday by the law of the applicable jurisdiction, such day will be omitted from the computation.

17.2.2 A calendar day of twenty-four hours measured from midnight to the next midnight shall constitute a day.

General:

17.3 Should DISTRICT or CONTRACTOR suffer injury or damage to person or property because of any error, omission or act of the other party or of any of the other party's employees or agents or others for whose acts the other party is legally liable, claim will be made in writing to the other party within a reasonable time of the first observance of such injury or damage. The provisions of this paragraph 17.3 shall not be construed as a substitute for or a waiver of the provisions of any applicable statute of limitations or repose.

17.4 The duties and obligations imposed by these General Conditions and the rights and remedies available hereunder to the parties hereto, and, in particular but without limitation, the warranties, guarantees and obligations imposed upon CONTRACTOR by paragraphs 6.30, 13.1, 13.12, 13.14, 14.3 and 15.2 and all of the rights and remedies available to DISTRICT and ENGINEER thereunder, are in addition, and are not to be construed in any way as a limitation of, any rights and remedies available to any or all of them which are otherwise imposed or available by Laws or Regulations, by special warranty or guarantee or by other

Section IV - General Conditions

provisions of the Contract Documents, and the provisions of this paragraph will be as effective as if repeated specifically in the Contract Documents in connection with each particular duty, obligation, right and remedy to which they apply. All representations, warranties and guarantees made in the Contract Documents will survive final payment and termination or completion of the Agreement.

Section V - Special Conditions

Special Notice Regarding Contract Unit Prices and the Price for Liquid Asphalt

CONTRACTOR and DISTRICT acknowledge and agree that this is a unit price contract extending for a one year period, and that the unit prices in the contract are heavily dependent upon the price of liquid asphalt which is heavily dependent upon the price of oil. Accordingly, DISTRICT and CONTRACTOR agree that should there be an increase or decrease in the price of liquid asphalt of more than five percent in any 30-day period, the contract price may be adjusted by mutual agreement between DISTRICT and CONTRACTOR.

It shall be the obligation of the CONTRACTOR to document any such increase in the price of liquid asphalt and to provide information satisfactory to DISTRICT evidencing the increase. The CONTRACTOR shall also have a corresponding obligation to bring any decrease in the price of liquid asphalt to the attention of DISTRICT with appropriate supporting documentation. As part of this consideration, the DISTRICT shall review the State of North Carolina Department of Transportation Pavement Construction Section's Terminal FOB Asphalt Binder Prices, as published monthly on the NCDOT website:

<https://connect.ncdot.gov/projects/construction/Pages/Pavement-Construction-Prices.aspx>

CONTRACTOR is advised that no adjustment of contract unit prices, for asphalt related items, will be considered for work completed within the first 30-day period of the contract. During that time, work shall be paid at the original unit prices in the contract.

Upon receipt and satisfactory review of a documented increase or decrease, the unit prices for the work described in this contract shall be adjusted downward or upward immediately. The increase or decrease shall be documented by an appropriate Change Order signed by an authorized representative of the DISTRICT and the CONTRACTOR.

Special Notice Regarding CONTRACTOR'S Activity at Individual Job Sites:

Restoration work by the CONTRACTOR at individual job sites may require closure of roads/ lanes to through traffic for limited periods. In such cases, the CONTRACTOR shall obtain road/lane closure permits as required by the local municipality, comply with the conditions of such permits, and detour the through traffic. Local traffic shall be maintained at all times and passible access shall be provided to all residence and business driveways.

When roads/lanes are closed, appropriate Fire Department, Police Office, Public Transit, EOC (Emergency Operations Center) and School System shall be notified by the CONTRACTOR. In addition, the CONTRACTOR shall notify businesses and residences that are directly affected and coordinate with DISTRICT staff. DISTRICT shall make no separate payment for this requirement.

The CONTRACTOR is advised to carefully review Section IV - General Conditions, Section VI - Specifications and Details, and other sections of these contract documents for more detailed information on the requirements for each work site.

DISTRICT staff will be available for consultation in such situations, but responsibility of obtaining subject permits will remain with CONTRACTOR.

Section VI – Specifications and Details

1. It is imperative that the asphalt restoration work be completed in the shortest time frame possible to avoid inconveniencing the traveling public, to reduce the cost of restoration and to protect the public health and safety.
2. For roadways classified as **high priority** by the Metropolitan Sewerage District of Buncombe County, NC (DISTRICT), **including all highways maintained by the North Carolina Department of Transportation**, it shall be required that restoration work take place on the **same day** the maintenance work has been completed. In order to accomplish this, the DISTRICT shall notify the CONTRACTOR **in advance** of the need for restoration with an approximate time that the maintenance work will be completed. Failure to restore the asphalt as specified herein will result in appropriate corrective actions by the DISTRICT as specified in *Section IV - General Conditions* of the contract documents. (This could include termination of the contract.) DISTRICT reserves the right to issue a penalty of \$200.00 per day for failure to restore the asphalt, as specified herein, for each repair left unattended after the first day, excluding overlays.
3. For roadways not classified as high priority by the DISTRICT, all repairs must be made within five (5) business days from notification by DISTRICT. The CONTRACTOR shall be responsible and liable for the maintenance of all repairs after the five (5) business days of notification for the restoration. DISTRICT shall be responsible for the maintenance of the repair for the first five (5) business days or until the CONTRACTOR begins restoration work depending on which takes place first. When the CONTRACTOR completes the restoration, the CONTRACTOR is to notify DISTRICT to request the appropriate inspection of the work. The CONTRACTOR will pick up all safety equipment left at the site by DISTRICT and return it to DISTRICT at 2028 Riverside Drive on a weekly basis. DISTRICT reserves the right to issue a penalty of \$200.00 per day for failure to restore the asphalt, as specified herein, for each repair left unattended after the first day, excluding overlays.
4. During winter when the asphalt plants are closed and hot-mix asphalt is not available, the CONTRACTOR shall make repairs with cold patch, or other acceptable semi-permanent type of repair, within time frames as specified in Items 1 & 2 above. When production of hot-mix asphalt resumes, the cold-patch repairs shall be replaced within two weeks, in accordance with these specifications and details.
5. DISTRICT reserves the right to eliminate and/or limit the use of cold patch or other semi-permanent repair material on this contract. Such action by DISTRICT shall be provided in writing to CONTRACTOR. The bidder acknowledges and agrees that it shall have no claim or breach of CONTRACTOR misrepresentation arising out of any such reduction in quantity or elimination of such work.
6. CONTRACTOR shall be responsible for verifying that the maintenance repair work has been left in accordance with the details herein attached prior to the placement of the restoration work. This responsibility shall be limited to verifying that the maintenance work was over-cut by one foot, or as necessary, saw cut straight and the top eight inches has been appropriately compacted. When the CONTRACTOR finds that the maintenance work does not comply to the requirements of the details, the CONTRACTOR shall notify DISTRICT of the need for additional maintenance work prior to the placement of the restoration work. The CONTRACTOR shall be paid a unit price for the site response to a repair that is not ready for restoration. All overlays must be completed within two weeks where required as a part of the restoration.
7. DISTRICT Maintenance work shall be left at grade in order to open roadways to traffic. It shall be the CONTRACTOR's responsibility to remove and dispose of the compacted aggregate and/or the semi-permanent repair to the depth required by the appropriate detail required for each repair.

Section VI – Specifications and Details

8. Unsatisfactory asphalt restoration work shall be removed by DISTRICT. When the failure is due to the restoration work of the CONTRACTOR of maintenance work verified as acceptable by the CONTRACTOR, the CONTRACTOR shall perform the second restoration at no cost to DISTRICT. When the failure is due to the original maintenance work performed by the DISTRICT, the CONTRACTOR shall be paid the appropriate unit price for the second restoration. **The CONTRACTOR's warranty period shall be for two years.** The DISTRICT reserves the right to hire other Contractors to repair defective work and to collect the cost of the warranty repairs from the CONTRACTOR when the CONTRACTOR fails to honor the warranty claim in a timely manner.
9. CONTRACTOR shall receive a minimum unit price for each asphalt restoration regardless of the quantities required for restoration.
10. CONTRACTOR's work shall be in accordance with these specifications and standard details. All asphalt materials shall be in accordance with the North Carolina Department of Transportation specifications and/or municipality requirements in the location where work occurs.
11. CONTRACTOR is advised that the bid sheets for this contract include items for Bituminous Concrete Binder Course Type I 19.0C asphalt mix. The I 19.0C mix is specified in 4-inch and 6-inch depths at areas of less than and greater than 25 square feet. These mix types and depths have been included in the contract to account for the wide variety of situations that may be encountered in the one year paving contract. The I 19.0C mix shall be acceptable only as "binder course" beneath a surface course and is not approved for a surface course in a finished patch.
12. Speaking generally, the S9.5B mix shall only be acceptable for use if approved by the DISTRICT prior to placement. It should not be used for binder course material.
13. CONTRACTOR may substitute S9.5C mix surface course material for binder course material, as approved by the North Carolina DOT or appropriate municipality where work occurs, to eliminate the need for two materials where called for in the details.
14. When S9.5B mix is utilized for the surface course, CONTRACTOR shall work fines in the mix to the surface to facilitate a smooth finish that is acceptable to the NCDOT or other municipality as appropriate.
15. When pavement replacement destroys existing line striping, new line striping of the same kind shall be provided in accordance with the requirements of the NCDOT, the City of Asheville, or other controlling agency, as appropriate. This requirement is further specified in this section Item 10 above, and Section IX Measure and Pay Item 4.3.00 of these contract documents. Failure to replace line striping per controlling agency specifications may subject CONTRACTOR to any liability claims arising out or related to a failure to replace line striping.
16. CONTRACTOR shall notify DISTRICT to obtain all extensions of time when weather conditions or other conditions do not allow for the placement of the restoration work within the specified time period of notification. DISTRICT, in its discretion, may grant additional time to complete the work. **If the CONTRACTOR fails to notify DISTRICT of the need for additional time, the CONTRACTOR shall be responsible for any penalty levied by the appropriate municipality for violation of the street cut permit. In addition, the CONTRACTOR shall be responsible for any injury to person or property resulting from the street cut and shall indemnify, defend and hold harmless DISTRICT from and against any claim for injury to person or property resulting from CONTRACTOR's failure to timely perform asphalt restoration work.**

Section VI – Specifications and Details

17. CONTRACTOR shall invoice DISTRICT monthly for work done. DISTRICT shall pay the monthly invoices after satisfactory receipt and review and after verification of acceptability of the work from the governing body within whose jurisdiction the work was done. Billing must be in an acceptable format that includes the following: invoice number, date, permit number or work order number, location, size, item number, item price, and total price. A sample form for asphalt and concrete billing shall be provided at the pre-bid meeting. DISTRICT reserves the right to withhold retainage on all work undertaken in accordance with North Carolina General Statutes 143-134.1.
18. Nothing in this section shall be deemed to preclude DISTRICT from withholding full or partial payment for defective work or work that has not been fully completed in accordance to the project specifications and contract documents or work that has not been completed to the satisfaction of DISTRICT.
19. The successful bidder shall provide one hundred percent (100%) performance and payment bonds prior to the execution of the contract by DISTRICT and within ten days after receipt of the Notice of Award. Failure to execute the contract or provide the performance and payment bonds will void the contract.
20. The minimum insurance requirements shall be those indicated on the form provided and shall include general liability insurance coverage, workers' compensation insurance coverage, and liability insurance coverage for all vehicles used by the CONTRACTOR in doing the street repair work.
21. If requested by DISTRICT, CONTRACTOR shall provide satisfactory evidence to the DISTRICT of its financial ability to carry out the terms of the contract. This process will include the items outlined below.
 1. A list of all projects completed in the last 5 years (minimum of three) with a scope equal to or larger than this project.
 2. A list of equipment available to perform the work with photos for same.
 3. A minimum of three (3) references from projects of a scope equal to or larger than this project.
 4. DISTRICT reserves the right to request financial information.
22. CONTRACTOR shall comply with all Federal, State and Local ordinances and hold harmless DISTRICT for any violation.
23. The Metropolitan Sewerage District of Buncombe County, North Carolina, is an equal opportunity employer. DISTRICT fully complies with all applicable laws which prohibit discrimination on the basis of race, color, religion, sex, national origin, age, or disability. CONTRACTOR represents to DISTRICT that it does not discriminate on the basis of race, color, religion, sex, national origin, age or disability in its employment opportunities, programs, services or activities. As a condition of this contract, CONTRACTOR agrees and warrants and represents that it will comply with the E-Verify hiring requirements of Article 2 of Chapter 64 of the North Carolina General Statutes. If CONTRACTOR utilizes a subcontractor to perform any part of the work included in the Contract, CONTRACTOR shall require the subcontractor to comply with the requirements of Article 2 of Chapter 64 of the North Carolina General Statutes. See item 28 below for additional information regarding sub-contracting.
24. Brick and Concrete Restorations of sidewalks total quantities for the year can only be estimated, and are to be used for comparison purposes. Specifications for this work shall comply with the most current municipality approved specifications for the area where work occurs.

Section VI – Specifications and Details

25. CONTRACTOR shall supervise and direct the Work competently and efficiently, devoting such attention thereto and applying such skills and expertise as may be necessary to perform the Work in accordance with the Contract Documents. CONTRACTOR shall be solely responsible for the means, methods, techniques, sequences and procedures of construction; but CONTRACTOR shall not be responsible for the negligence of others in the design or selection of specific means, method, technique, sequence or procedure of construction which is indicated in and required by the Contract Documents. CONTRACTOR shall be responsible to see that the finished Work complies with the Contract Documents.
26. CONTRACTOR agrees to defend, indemnify and hold harmless DISTRICT from and against any claim for injury to person or property arising out of the asphalt restoration work performed pursuant to this Agreement. Such indemnification shall include reasonable attorney's fees and expert witness fees incurred by DISTRICT in defense of any such claim. DISTRICT agrees to notify CONTRACTOR in writing within twenty days of receipt of a claim for injury to person or property arising out of the asphalt restoration work. If CONTRACTOR fails, within a reasonable time, to assume the defense of any such claim, then DISTRICT shall have the right to defend the claim and to recover the costs of defense, including reasonable attorney's fees and expert witness fees from the CONTRACTOR.
27. CONTRACTOR shall keep on the Work at all times during its progress a **Competent Resident Superintendent**, who shall not be replaced without written notice to the DISTRICT except under extraordinary circumstances. The superintendent will be the CONTRACTOR's representative at the site and shall have authority to act on behalf of CONTRACTOR. All communications given to the superintendent shall be as binding as if given to CONTRACTOR.
28. CONTRACTOR **shall not sub-contract more than 20%** of the work and all sub-contractors must be pre-approved by the DISTRICT in writing. CONTRACTOR shall be responsible for the work and actions of the sub-contractor.
29. DISTRICT reserves the right to have work performed under this contract in City of Asheville Rights of Way. In such cases, the following will apply:
 1. DISTRICT will communicate specific written instructions to CONTRACTOR as to what tasks are to be completed at each site.
 2. All pavement restoration by CONTRACTOR at the site shall meet appropriate City of Asheville standards.
 3. Payment will be made per contract unit pricing.
30. As stated in item 8 above, CONTRACTOR's warranty period shall be two (2) years. This warranty will cover all work items performed as part of this contract.
31. This contract will be issued for one (1) year (July 1, 2024 – June 30, 2025), not to exceed the total amount bid without written approval by the DISTRICT. All terms and conditions, including costs, being equal, the DISTRICT reserves the right to extend the contract for two (2) additional years, in one year increments, if DISTRICT determines it is in its best interest to do so. The DISTRICT will review the contract prior to the end of each fiscal year and make a decision as to whether or not to extend the contract for an additional year.
32. DISTRICT reserves the right to cancel this contract with a 7-day written notice in the event that the CONTRACTOR fails to perform the work in accordance with the contract requirements.
33. CONTRACTOR must be licensed as provided in Chapter 87 of the North Carolina General Statutes, holding either a Highway or Unclassified license. Proper documentation for said license is to be provided to the DISTRICT.

Section VI – Specifications and Details

34. CONTRACTOR is advised that the DISTRICT service area has expanded to include the Cane Creek Sewer District which is in northern Henderson County. Maps showing the previous MSD boundary and the new service area for the Cane Creek boundary are attached for reference. The terms, conditions, and unit pricing of this Contract shall apply to any work the DISTRICT instructs CONTRACTOR to perform within the entire MSD service area.

Depths of Paving Courses for Pavement Repairs Requiring Binder			
Classification	Base Course	Binder	Surface Course
Municipal Street*	8" ABC compacted to 100% standard proctor	4" Asphalt binder course Type 1 19.OC or S9.5B compacted to 92% maximum lab density	2" S9.5C compacted to 90% of maximum lab density
City of Asheville	8" ABC compacted to 100% standard proctor	6" Asphalt binder course Type 1 19.OC compacted to 92% maximum lab density	2" S9.5C compacted to 90% of maximum lab density
Biltmore Forest	8" ABC compacted to 100% standard proctor	4" Asphalt binder course Type 1 19.OC compacted to 92% maximum lab density	1" S9.5C compacted to 90% of maximum lab density
NCDOT Road (\geq 12" Dia. Pipe)	N/A	11" Asphalt binder course Type 1 19.OC compacted to 92% maximum lab density	2" S9.5C compacted to 90% of maximum lab density
NCDOT Road (< 12" Dia. Pipe)	8" ABC compacted to 95% standard proctor	6" Asphalt binder course Type 1 19.OC compacted to 92% maximum lab density (in two 3" lifts)	3" S9.5C compacted to 90% of maximum lab density (in two 1.5" lifts)
Heavy Duty Commercial Drive	8" ABC compacted to 100% standard proctor	4" Asphalt binder course Type 1 19.OC compacted to 92% maximum lab density	1.5" S9.5C compacted to 90% of maximum lab density

* Municipal streets include all streets that fall under the jurisdictions of Black Mountain, Montreat, Weaverville, and Woodfin.

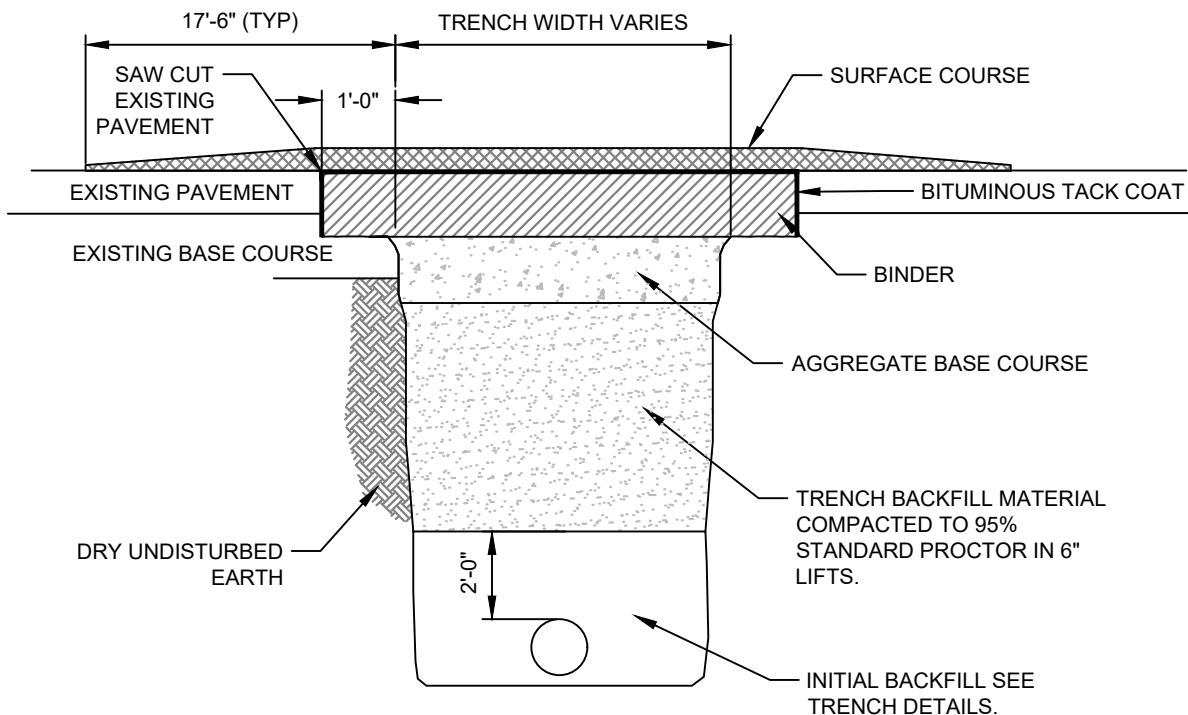

NOTES:

1. EDGES ARE TO BE SAWED WITH A CONCRETE SAW TO A NEAT SQUARED EDGE, AND BROOMED CLEAN OF DUST PRIOR TO APPLICATION OF TACK COAT.
2. EDGES AND OVERLAY AREAS TO BE TACKED WITH RC OR AC-1 SPECIAL TACK

STANDARD DETAIL	
Metropolitan Sewerage District of Buncombe County, North Carolina	
TYPICAL PAVEMENT REPAIR	
DATE APPROVED: MARCH 2017	4.08 - 01

Depths of Paving Courses for Pavement Repairs Not Requiring Binder			
Classification	Base Course	Binder	Surface Course
Light Duty Commercial Drive	8" ABC compacted to 100% standard proctor	No binder needed	2" S9.5C compacted to 90% of maximum lab density
Residential Drive	8" ABC compacted to 100% standard proctor	No binder needed	2" S9.5C compacted to 90% of maximum lab density

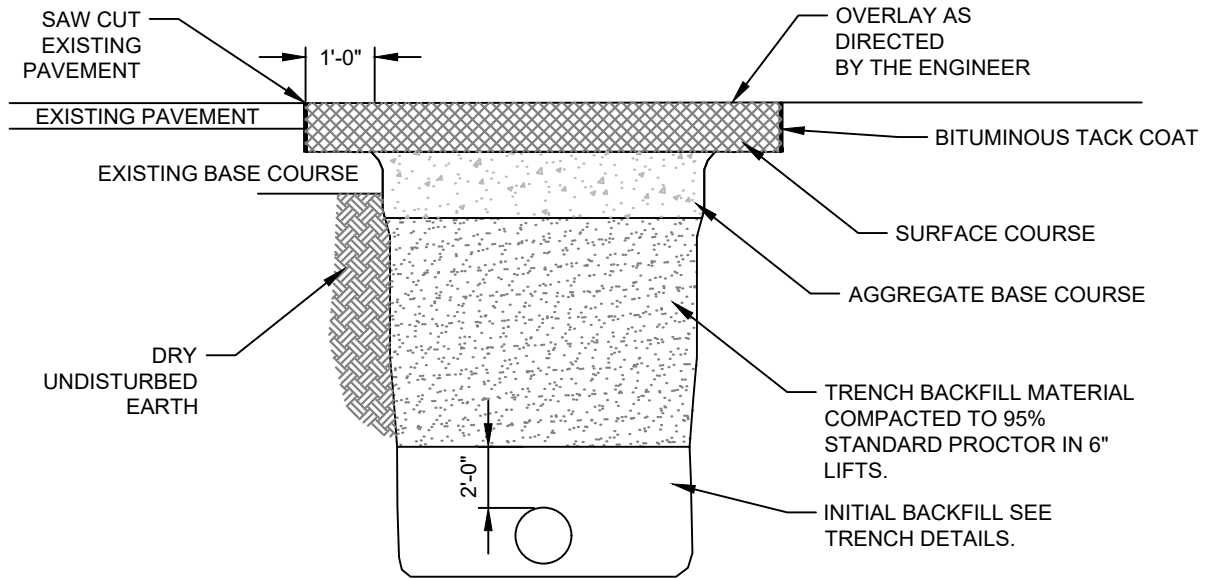

PRIVATE DRIVE AND PARKING LOT PAVEMENT REPAIR
(IN AREAS OF NON-HEAVY DUTY TRAFFIC)
N.T.S.

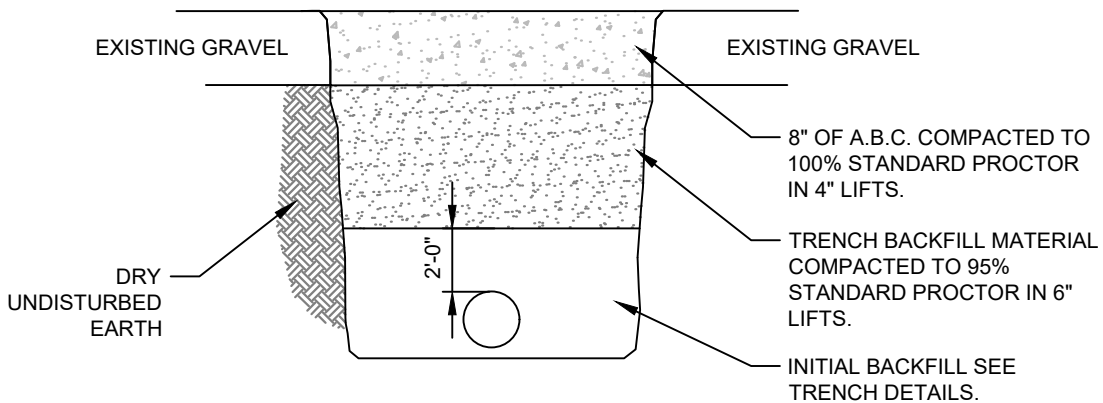

GRAVEL SURFACE REPAIR
N.T.S.

NOTES:

1. EDGES ARE TO BE SAW CUT WITH A CONCRETE SAW TO A NEAT SQUARED EDGE, AND BROOMED CLEAN OF DUST PRIOR TO APPLICATION OF TACK.
2. PAVEMENT REPAIR DETAIL SHALL BE USED FOR ALL BITUMINOUS SURFACES WHICH ARE NOT UNDER CONTROL OF THE N.C.D.O.T. OR BILTMORE FOREST.

STANDARD DETAIL	
Metropolitan Sewerage District of Buncombe County, North Carolina	
PERMANENT PAVEMENT & GRAVEL SURFACE REPAIR	
DATE APPROVED: MARCH 2017	4.08 - 02

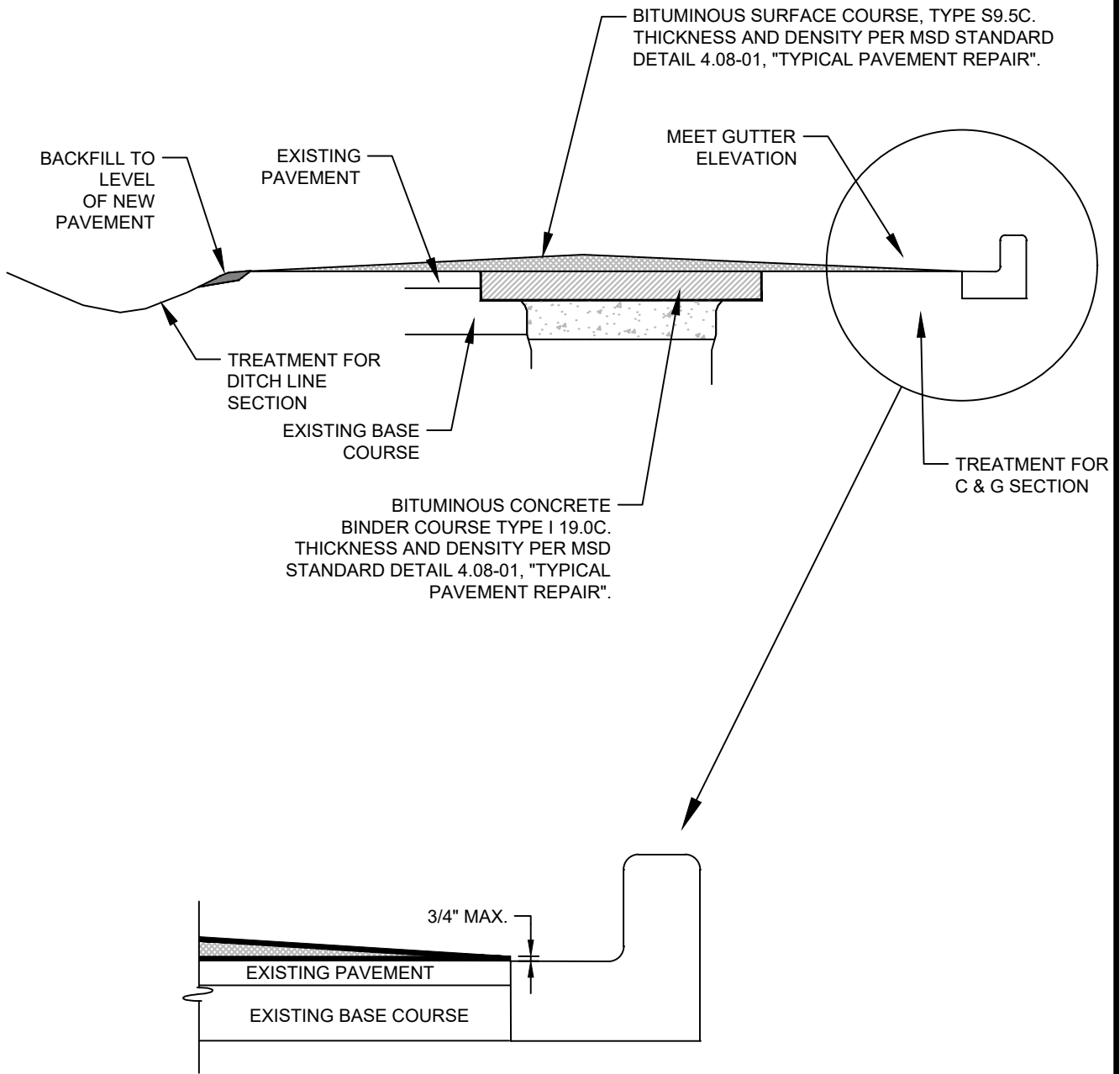

NOTES:

1. EDGES ARE TO BE SAWED WITH A CONCRETE SAW TO A NEAT SQUARED EDGE, AND BROOMED CLEAN OF DUST PRIOR TO APPLICATION OF TACK COAT.
2. CURB & GUTTER STREETS REQUIRE MILLING IN ACCORDANCE WITH LOCAL GOVERNMENT REQUIREMENTS.

REV: June 2020 KMK

STANDARD DETAIL	
Metropolitan Sewerage District of Buncombe County, North Carolina	
FULL WIDTH OVERLAY DETAIL	
DATE APPROVED: MARCH 2017	4.08 - 03

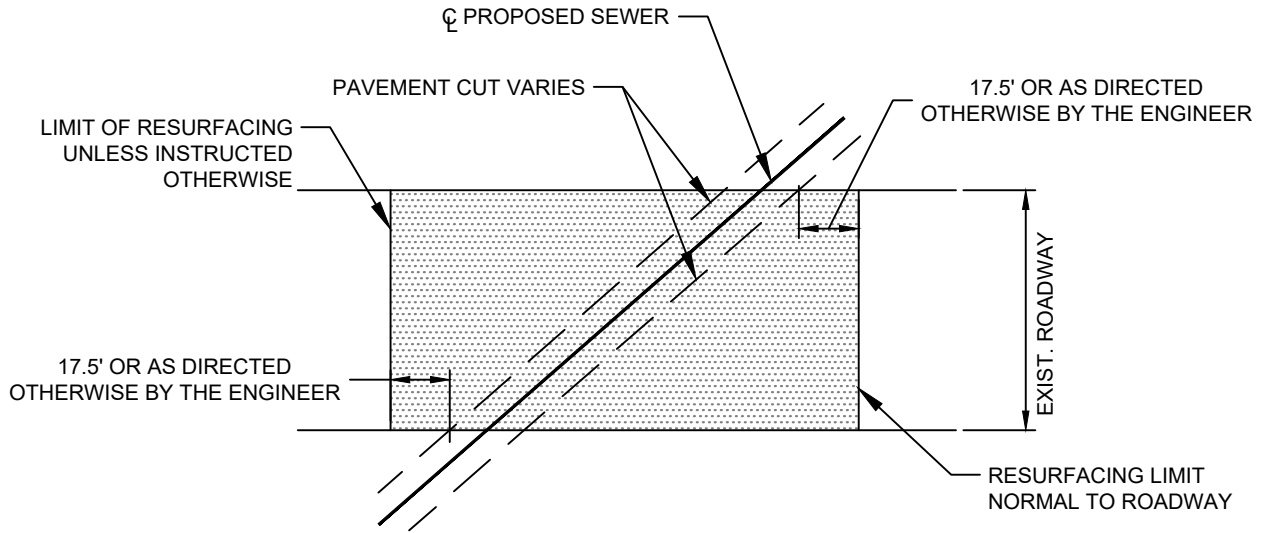

NOTE: APPLY TACK COAT TO ENTIRE AREA TO BE RESURFACED

TRANSVERSE CUT
N.T.S.

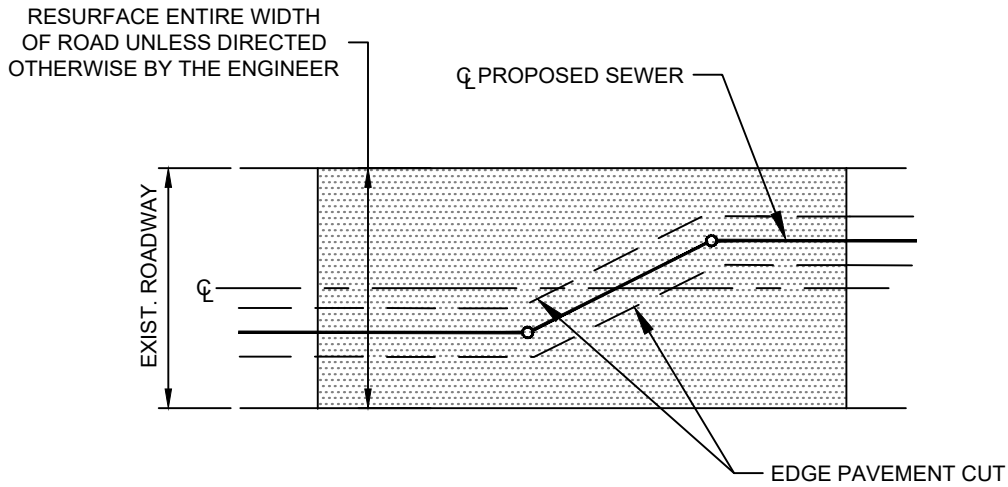

LONGITUDINAL CUTS
N.T.S.

THIS DETAIL FOR PAVING
CONTRACTS ONLY

STANDARD DETAIL	
Metropolitan Sewerage District of Buncombe County, North Carolina	
BITUMINOUS PAVEMENT RESURFACING WIDTH	
DATE APPROVED: 1998	--

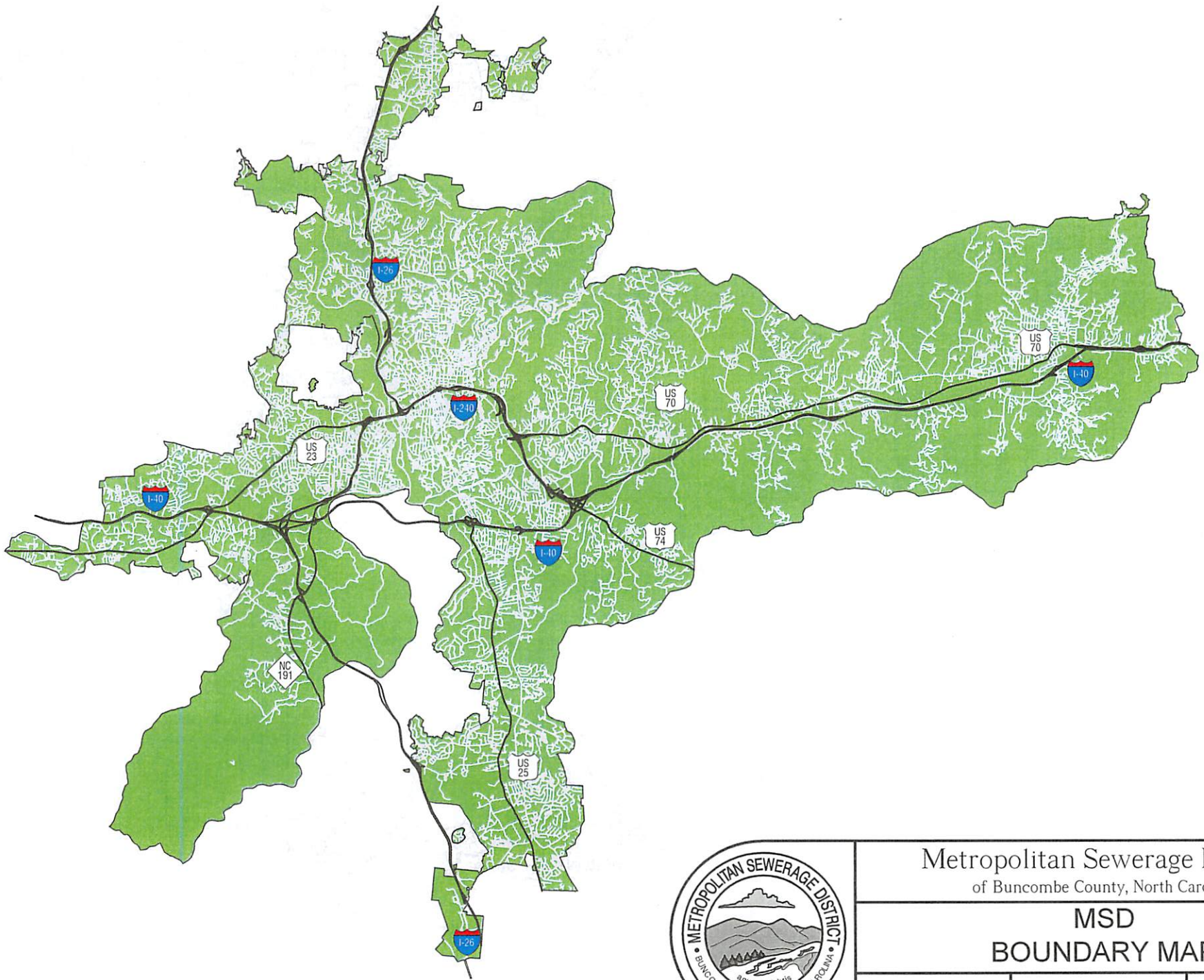

Metropolitan Sewerage District
of Buncombe County, North Carolina

**MSD
BOUNDARY MAP**

DRAWN BY: JO	DATE: 02/03/2020	SCALE: N.T.S.
--------------	------------------	---------------

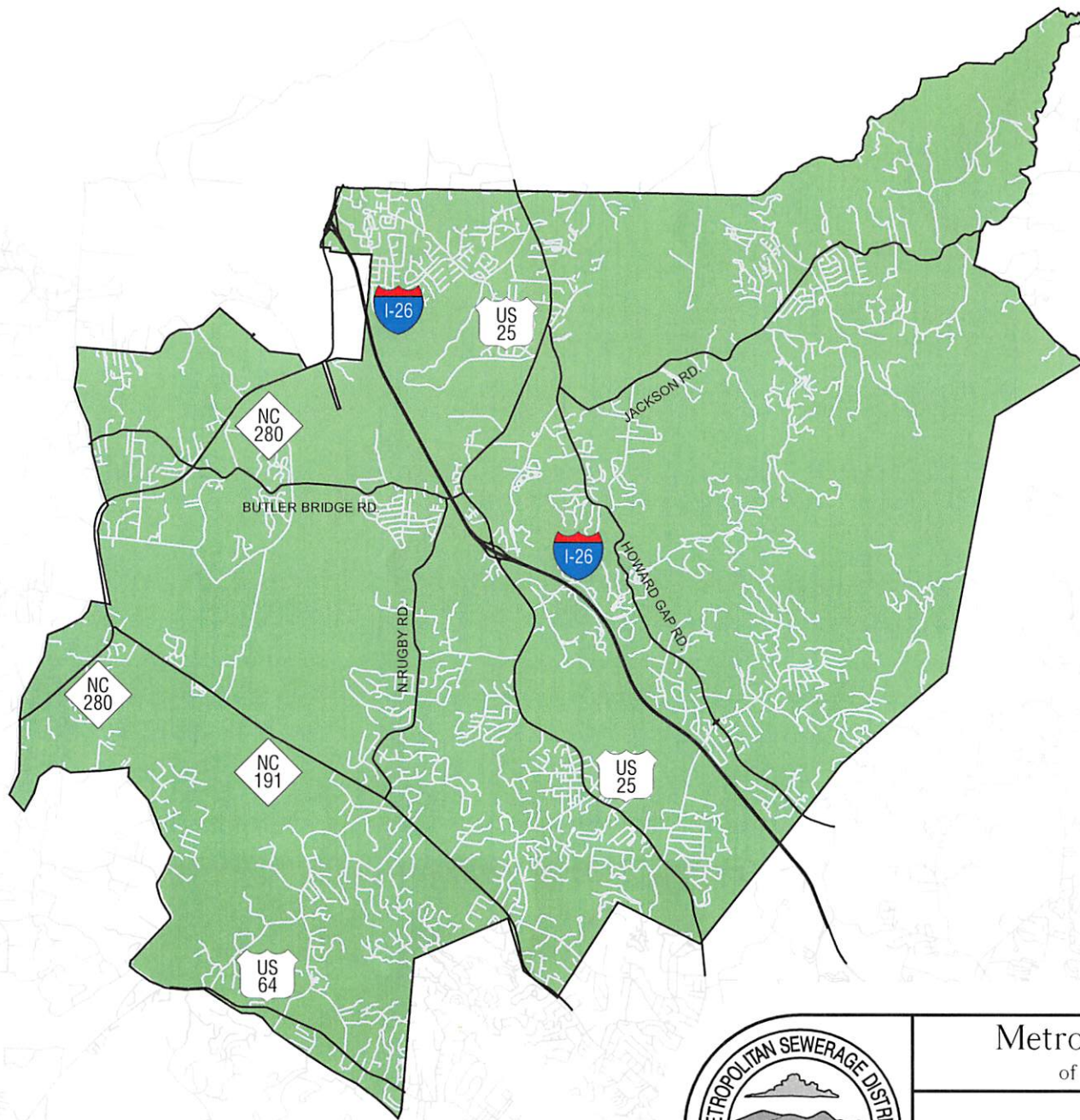

Metropolitan Sewerage District
of Buncombe County, North Carolina

**CANE CREEK
BOUNDARY MAP**

DRAWN BY: JO

DATE: 02/03/2020

SCALE: N.T.S.

TABLE OF CONTENTS

<u>ARTICLE NUMBER</u>	<u>DESCRIPTION</u>	<u>PAGE</u>
I	Application	1
II	Minority Business Enterprise Goals	1
III	Subcontractor Payment Requirements	2
IV	Program Compliance Requirements	3
V	Checklist for Review of Good Faith Efforts	4
VI	MBE Utilization Commitment (Form 1)	5
VII	Contractor Certification Regarding Subcontracting Practices (Form 2)	6
VIII 7	MBE Letter of Intent (Form 3)	
IX	Guidelines for Recruitment and Selection of MBE	8

ARTICLE I: APPLICATION

The requirements of the Metropolitan Sewerage District (DISTRICT) Guidelines for Recruitment and Selection of Minority Businesses for Participation in Sewage Construction Contracts are hereby made a part of these contract documents. These requirements shall apply to all contractors regardless of ownership. A copy of the Metropolitan Sewerage District Guidelines for Recruitment and Selection of Minority Businesses for Participation in Sewage Construction Contracts is attached:

ARTICLE II: MINORITY BUSINESS ENTERPRISE GOALS

The goal for Minority Business Enterprise (MBE) participation on DISTRICT projects has been set at **Twelve (12)** percent.

The Bidder shall provide, with the bid, documented proof in the form of MBE Form 1, MBE UTILIZATION COMMITMENT, that these goals have been met or exceeded;

OR

If minority participation is less than Twelve (12) percent, provide with the bid, 1) the Checklist for Review of Good Faith Efforts, and 2) MBE Form 1 (MBE UTILIZATION COMMITMENT) identifying the amount of MBE participation.

NOTE: If the Bidder awards ALL subcontracts to MBE's, the Checklist for Review of Good Faith Efforts listed above will not be required; however, this shall be noted on MBE Form 1.

OR

If there is no minority participation, provide with the bid, MBE Form 2, CERTIFICATION REGARDING SUBCONTRACTING PRACTICES, and upon request, information sufficient for the DISTRICT to determine that the Bidder does not customarily subcontract work on this type of project.

Failure to provide this evidence may result in rejection of the bid and award to another responsible, responsive bidder.

NOTE REGARDING MBE FORM 3:

Bidders employing MBE's shall provide with the bid, or within 72 hours from the receipt of bids, a Letter of Intent (**MBE Form 3**), complete with a description of the scope of services and dollar value for each MBE firm proposed for use in this contract. Failure to provide the documentation as listed in these provisions may result in rejection of the bid and award to another responsible, responsive bidder. The DISTRICT reserves the right to waive any irregularities in MBE documentation if they can be resolved prior to award of the contract, and the DISTRICT finds it to be in its best interest to do so and award the contract.

ARTICLE III: SUBCONTRACTOR PAYMENT REQUIREMENTS

North Carolina General Statute 143-134.1 states that the percentage of retainage on payments made by the prime CONTRACTOR to the subcontractor shall not exceed the percentage of retainage on payments made by the DISTRICT to the prime CONTRACTOR. Failure to comply with this provision shall be considered a breach of the contract, and the contract may be terminated in accordance with the termination provisions of the contract.

The CONTRACTOR shall provide an itemized statement of payments to each MBE subcontractor with each request for payment or before final payment is processed.

(THIS SPACE IS INTENTIONALLY BLANK.)

ARTICLE IV: PROGRAM COMPLIANCE REQUIREMENTS

All written statements, certifications or intentions made by the Bidder shall become a part of the agreement between the CONTRACTOR and DISTRICT for performance of this contract. Failure to comply with any of these statements, certifications or intentions, or with the MBE Guidelines shall constitute a breach of the contract. A determination by the DISTRICT that any information submitted either prior to award of the contract or during the performance of the contract is inaccurate, false or incomplete, shall constitute a breach of the contract. Any such breach may result in termination of the contract in accordance with the termination provisions contained in the contract. It shall be solely at the option of the DISTRICT whether to terminate the contract for breach.

In determining whether a CONTRACTOR has made good faith efforts to include minority participation, DISTRICT will evaluate all efforts made by the CONTRACTOR and will determine compliance. DISTRICT may take into account any or all of the following:

1. Whether the Bidder attended any pre-bid meetings scheduled by the DISTRICT;
2. Whether the Bidder advertised in general circulation, trade association, and minority-focused media concerning the subcontracting opportunities;
3. Whether the Bidder provided written notice to a minimum of three MBE's for each portion of the work subcontracted, that their interest in the contract was being solicited in sufficient time to allow the MBE's to participate effectively;
4. Whether the Bidder followed up initial solicitations of interest by contacting MBE's to determine with certainty whether the MBE's were interested;
5. Whether the Bidder selected portions of the work to be performed by MBE's in order to increase the likelihood of meeting MBE goals (including, where appropriate, breaking down contracts into economically feasible units to facilitate MBE participation);
6. Whether the Bidder provided interested MBE's with adequate information about the Plans, Specifications and requirements of the contract;
7. Whether the Bidder negotiated in good faith with interested MBE's and not rejecting MBE's as unqualified without sound reasons based upon a thorough investigation of their capabilities.

Section VII - Minority Business Enterprises

ARTICLE V - CHECKLIST FOR REVIEW OF GOOD FAITH EFFORTS

(Must be submitted with Bid under certain conditions – See Article II)

1. Have you attended any of the pre-bid conferences scheduled?
() Yes () No () None Scheduled

2. Have you advertised for at least three (3) consecutive days in general circulation, trade association, construction and minority focused media regarding subcontracting opportunities with your firm at least fifteen (15) days prior to bid opening on formal projects?
() Yes () No (Show how and attach proof)

3. Have you utilized the services of state and/or federal minority business assistance, minority contractors' group, available minority community organizations, , and other organizations that provide assistance in the recruitment and placement of minorities and women? () Yes
() No (Show how and attach proof)

4. Have you provided interested MBE's with adequate and equal access to information about the plans, specifications and requirements of the contract and insurance or licenses?
() Yes () No

5. Did you provide written notice to all appropriate certified MBE's within the identified subcontracting / supplier / service categories that their interest in the contract was being solicited and in sufficient time to allow the MBE'S to participate? Additionally, did the solicitation contain a description and location of the project, the work for which the subcontractors' bids are being solicited, date, time and location where the subcontractors' bids are to be submitted, locations where bidding documents could be reviewed?
() Yes () No

6. Have you selected portions of the work to be performed by MBE's in order to increase the likelihood of meeting MBE's goals including breaking it into economically feasible units where appropriate?
() Yes () No

7. Have you designated someone in your firm to be the single contact for MBE's that may have questions, etc.? () Yes () No (Please indicate name of person and title)
_____.

8. Did you follow up initial solicitations of interest by contacting MBE's to determine with certainty whether they are interested in bidding? () Yes () No

9. Did you negotiate in good faith with interested MBE's, not rejecting MBE's as unqualified without sound reasons based on a thorough investigation of their capabilities?
() Yes () No (Show how)

COMPANY NAME OF BIDDER:

Signature

Title

ARTICLE VI: MBE FORM 1

(Must be submitted with Bid if any subcontractors are used.)

MBE UTILIZATION COMMITMENT

We, _____, do certify that on the

**FY 2025 Contract for the Restoration of Non-City of Asheville Road Rights-of-Way
Following MSD Wastewater Collection System Maintenance, Project No. 2002101**

that we will expend a minimum of _____% of the total dollar amount of the contract with minority business enterprises. MBE's will be employed as construction subcontractors, vendors, suppliers or providers of professional services. Such work will be subcontracted to the following firms listed below. If the Bidder intends to subcontract, this form must be completed regardless of the amount or lack of participation attained.

<u>Name and Phone Number of Firm</u>	<u>Indicate MBE</u>	<u>Description of Work</u>	<u>% of Contract</u>
------------------------------------------	-------------------------	--------------------------------	----------------------

The undersigned will enter into a formal agreement with Minority Firms for work listed in this schedule conditional upon execution of a contract with the **Metropolitan Sewerage District**. Failure to fulfill this commitment may constitute a breach of the contract.

The undersigned hereby certifies that he or she has read the terms of this commitment and is authorized to bind the Bidder to the commitment herein set forth.

Date: _____

(Name of Bidder)

By: _____

Title: _____

ARTICLE VII: MBE FORM 2

(Must be completed with Bid if MBE Form 1 is not submitted)

CERTIFICATION REGARDING SUBCONTRACTING PRACTICES

We, _____, hereby certify that it is our intent to perform
(Name of Bidder)

100% of the work required for the **FY 2025 Contract for the Restoration of Non-City of Asheville Road Rights-of-Way Following MSD Wastewater Collection System Maintenance, Project No. 2002101.**

In making this certification, the Bidder states the following:

1. That the Bidder does not customarily subcontract elements of this type project, and normally performs and has the capability to perform and will perform all elements of the work on this Project with his/her own current work forces; and
2. That, if requested, the Bidder agrees to submit the following information after bid and before the award of the contract:
 - * List of the scope of services involved in this project.
 - * List of previous projects of this type that Bidder has performed with his/her forces.
 - * Payrolls from the above-mentioned jobs which illustrate Bidder's employee's job classifications needed to perform the elements of the work on the Project or a breakdown of Bidder's entire work force which illustrates the number of employees in each job classification.
 - * Name and phone number of the Field Supervisors for these jobs.
 - * List of equipment Bidder owns that has been used on previous projects.
 - * Copies of lease agreements for equipment that was leased.

The Bidder agrees to provide any additional information requested for the statement contained in Paragraph Number 1 above.

The undersigned hereby certifies that he or she has read this certification and is authorized to bind the Bidder to the commitments herein contained.

Date: _____

(Name of Bidder)

By: _____

Title: _____

ARTICLE VIII: MBE FORM 3

**LETTER OF INTENT TO PERFORM AS A SUBCONTRACTOR
OR
PROVIDE MATERIALS OR SERVICES**

SUBJECT: FY 2025 Contract for the Restoration of Non-City of Asheville Road Rights-of-Way Following MSD Wastewater Collection System Maintenance, Project No. 2002101

TO: _____
_ (Name of Prime Bidder)

The undersigned intends to perform work in connection with the above project as a Minority Business Enterprise.

The MBE status of the undersigned **is / is not** (circle one) certified by the Office of Historically Underutilized Businesses for the State of North Carolina. The DISTRICT encourages all qualified MBE's to become certified by this office.

The undersigned is prepared to perform the following described work or provide materials or services in connection with the above project (specify in detail particular work items, materials or services to be performed or provided):

at the following price: _____.

You have projected the following commencement date for such work, and the undersigned is projecting completion of such work as follows:

<u>Items</u>	Projected Commencement Date _____	Projected Completion Date _____
--------------	-----------------------------------------	---------------------------------------

Subcontracting at any tier must be reported and is subject to all MBE compliance requirements. This form shall be used for MBE subcontracting at any level.

Date: _____

Name of Minority Contractor

By: _____

Title: _____

ARTICLE IX: THE METROPOLITAN SEWERAGE DISTRICT
OF BUNCOMBE COUNTY, NORTH CAROLINA
GUIDELINES FOR RECRUITMENT AND SELECTION OF
MINORITY BUSINESSES FOR PARTICIPATION
IN SEWAGE CONSTRUCTION CONTRACTS

These guidelines establish goals for minority participation in single-prime and separate-prime sewage construction contracts. Legislation provides that public bodies shall have a verifiable percentage goal for participation by minority businesses in the total value of work for each project for which a contract or contracts are awarded. These guidelines are published to accomplish that end.

SECTION 1: INTENT AND APPLICATION OF GUIDELINES

It is the intent of these guidelines that The Metropolitan Sewerage District of Buncombe County, North Carolina, (DISTRICT) as awarding authority for sewage construction projects, and the contracts and subcontractors performing the construction contracts awarded, shall make a good faith effort to attain a verifiable goal of 12% participation by minority businesses in each construction project. Nothing contained in these guidelines shall be construed to require DISTRICT to award contracts to or to make purchases of materials or equipment from minority-business contractors who do not submit the lowest responsible responsive bid or bids.

These guidelines shall apply to all contracts for the erection, construction, alteration, or repair of any buildings or other construction projects when the entire cost of such work shall exceed \$100,000.00.

SECTION 2: DEFINITIONS

1. Minority - a person who is a citizen or lawful permanent resident of the United States and who is:
 - a. Black, that is, a person having origins in any of the black racial groups in Africa;
 - b. Hispanic, that is, a person of Spanish or Portuguese culture with origins in Mexico, South or Central America, or the Caribbean Islands, regardless of race;
 - c. Asian American, that is, a person having origins in any of the original peoples of the Far East, Southeast Asia, and Asia, the Indian subcontinent, the Pacific Islands;
 - d. American Indian or Alaskan Native, that is, a person having origins in any of the original peoples of North America; or
 - e. Female.

Section VII - Minority Business Enterprises

2. Minority Business - Means a business:
 - a. In which at least fifty-one percent (51%) is owned by one or more minority persons, or in the case of a corporation, in which at least fifty-one (51%) of the stock is owned by one or more minority persons; and
 - b. Of which the management and daily business operations are controlled by one or more of the minority persons who owns it.
3. District - The Metropolitan Sewerage District of Buncombe County, North Carolina.
4. Bidder - Any person, firm, partnership, corporation, association, or joint venture seeking to be awarded a public contract or subcontract.
5. Contract - A mutually binding legal relationship or any modification thereof obligating the Contractor to furnish labor, equipment, materials, or services for the erection, construction, alteration, or repair of any buildings or other construction projects and obligating the DISTRICT to pay for them.
6. Contractor - Any person, firm, partnership, corporation, association, or joint venture which has contracted with the DISTRICT to perform a Contract to which these guidelines apply.
7. Subcontractor - Any person, firm, partnership, corporation, association, or joint venture under contract with a Contractor for supplying materials or labor, equipment, materials or services. The subcontractor may or may not provide materials in his subcontract. Work subcontracted in an emergency and which could not have been anticipated is excluded as part of this program.
8. Verifiable goal - means:
 - a. For purposes of separate-prime contract system, that the DISTRICT has adopted written guidelines specifying the actions that will be taken to ensure a good faith effort in the recruitment and solicitation of minority businesses for participation in contracts awarded; and
 - b. For purposes of separate-prime contract system, that the DISTRICT has adopted written guidelines specifying the actions that the prime contractor must take to ensure a good faith effort in the recruitment and solicitation of minority businesses for participation in contracts awarded; the required actions must be documented in writing by the CONTRACTOR to the DISTRICT.

SECTION 3: RESPONSIBILITIES

1. The State of North Carolina has an established program in which it lists certified minority and women businesses persons who may qualify as Minority or Woman-owned Business Enterprises (MBE/WBE). The State of North Carolina accepts certification through the *Office for Historically Underutilized Businesses* (www.doa.state.nc.us/hub). Current information on the program, certification and searching for minority vendors can be found at this website.
2. DISTRICT/The Metropolitan Sewerage District of Buncombe County, North Carolina.

Under the single-prime contract system and the separate-prime contract system, the DISTRICT shall:

- a. Fully explain the bidder's responsibilities and this program at the pre-bid conference, if scheduled, conducted by the representative of the DISTRICT. Said conference will be open to all known and anticipated prime contractors, subcontractors, material suppliers, and other bidders.
- b. Be responsible for reviewing the apparent low bidder's compliance with the items listed in the proposal that must be complied with, if the bid is to be considered responsive and responsible. The DISTRICT reserves the right to reject any and all bids and to waive informalities.
- c. Identify or determine the work areas of a contract where MBE's may have an interest in performing contract work.

3. Prime Contractor(s)

Under the single-prime contract system and the separate-prime contract system, the prime contractor(s) shall:

- a. Attend the scheduled pre-bid conference.
- b. Identify or determine those work areas of a subcontract where MBEs may have an interest in performing subcontract work.
- c. Notify certified MBE's of potential subcontracting opportunities listed in the proposal at least ten (10) days prior to the scheduled day of bid opening. The notification will include the following:
 - (1) A description of the work for which the sub-bid is being solicited.
 - (2) The date, time and location where sub-bids are to be submitted.
 - (3) The name of the individual within the company who will be available to answer questions about the project.

Section VII - Minority Business Enterprises

- (4) Where bid documents may be reviewed.
- (5) Any special requirements that may exist, such as insurance, licenses, bonds and financial arrangements.

If there are more than three (3) certified MBE's in the area of the project, the Contractor(s) shall notify three (3), but may contact more, if the Contractor(s) so desires.

- d. During the bidding process, comply with the DISTRICT's requirements listed in the contract documents for minority participation.
- e. Submit with the bid a description of that portion of the work to be executed by MBE's expressed as a percentage of the total contract price.
- f. Upon being named the apparent low bidder, provide the necessary documentation as listed in the contract documents provided by the DISTRICT. Failure to comply with procedural requirements as defined in contract documents may render the bid as non-responsive and may result in rejection of the bid and award to the next lowest responsible and responsive bidder.
- g. During the construction of a project, if it becomes necessary to replace an MBE subcontractor, advise the DISTRICT.
- h. If during the construction of a project additional subcontracting opportunities become available, make a good faith effort to solicit bids from MBE's.

4. MBE Responsibilities

While MBE's are not required to become certified in order to participate in this program, it is recommended that they become certified in the State of North Carolina by the N.C. Office for Historically Underutilized Businesses and should take advantage of the appropriate technical assistance that is made available. In addition, MBE's who are contacted by the DISTRICT or bidders should respond promptly whether or not they wish to submit a bid.

SECTION 4: DISPUTE PROCEDURES

It is the policy of the DISTRICT that disputes with another person that involve a person's rights, duties or privileges, should be settled through informal procedures. To that end, MBE disputes arising under these guidelines should be resolved, if possible, by informal proceedings arranged by the General Manager or his designee.

Section VII - Minority Business Enterprises

SECTION 5: EFFECTIVE DATE

These guidelines became effective on July 17, 2002. Copies of these guidelines may be obtained from the MSD Construction Office, 2028 Riverside Drive, Asheville, North Carolina, 28804; telephone number (828) 254-9646.

SECTION 6: GUIDELINES AND COMPLIANCE DOCUMENTATION TO BE PART OF CONTRACT DOCUMENTS

These guidelines will be included in the contract to each construction bid package and provisions for documenting contractual compliance in providing for MBE participation in the construction program will be included in each construction bid package.

NON-COLLUSION AFFIDAVIT

State of North Carolina
County of Buncombe

_____, being first duly sworn, deposes and says that:

1) He/She is President of _____
(Company/Corporation), that has submitted the attached bid for **FY 2025 Contract for the Restoration of Non-City of Asheville Road Rights-of-Way Following MSD Wastewater Collection System Maintenance, Project No. 2002101.**

2) He/She is fully informed respecting the preparation and contents of the attached Bid and of all pertinent circumstances respecting such Bid;

3) Such Bid is genuine and is not a collusive or sham bid;

4) Neither the said Bidder nor any of its officers, partners, owners, agents, representatives, employees, or parties in interest, including this affiant, has in any way colluded, conspired, connived, or agreed, directly or indirectly with any other Bidder, firm, or person to submit a collusive or sham Bid in connection with such Contract, or has in any manner, directly or indirectly, sought by agreement or collusion or communication or conference with any other Bidder, firm, or person to fix the price or prices in the attached Bid or of any other Bidder, or to fix any overhead, profit, or cost element of the Bid price of any other Bidder, or to secure through any collusion, conspiracy, connivance or unlawful agreement any advantage against the Metropolitan Sewerage District of Buncombe County or any person interested in the proposed Contract; and

5) The price or prices quoted in the attached Bid are fair and proper and are not tainted by any collusion, conspiracy, connivance, or unlawful agreement on the part of the Bidder or any of its agents, representatives, owners, employees, or parties in interest, including this affiant.

Signed: _____

Title: _____

Subscribed and sworn before me this the _____ day of _____, 2024.

Notary Public (Seal)

My Commission Expires: _____

TABLE OF CONTENTS

<u>NO.</u>	<u>ITEM</u>
MP-1	Scope
MP-2	General
MP-3	Estimated Quantities
MP-4	<u>ASPHALT WORK ITEMS</u>
MP-4.1.00	Charge to respond to repairs not ready for restoration
MP-4.2.00	Bituminous Pavement Repairs and Resurfacing
MP-4.3.00	Pavement Marking
MP-4.4.00	Hand Formed Asphalt Curb
MP-4.6.00	Asphalt Milling
MP-5	<u>CONCRETE WORK ITEMS</u>
MP-5.1.00	Concrete Sidewalk to Specification
MP-5.2.00	Concrete Driveway to Specification
MP-5.3.00	Concrete Curb and Gutter to Specification

Section IX - Measurement and Payment

MP-1 **SCOPE**

This section covers methods of measurement and payment for items of work under this contract.

MP-2 **GENERAL**

The total bid price for each section of the contract shall cover all work required by the Contract Documents. All costs in connection with the proper and successful completion of the work including furnishing all materials, equipment, supplies, appurtenances, and performing all necessary labor and supervision to fully complete the work, shall be included in the unit and lump sum prices bid. All work not specifically set forth as a pay item in the Bid Form shall be considered as incidental.

MP-3 **ESTIMATED QUANTITIES**

All Estimated Quantities stipulated in the Bid Form or other Contract Documents are approximate and are to be used only a) as a basis for estimating the probable cost of the work and b) for the purpose of comparing the bids submitted for the work. The actual amounts of work done and materials furnished under unit price items may differ from the estimated quantities. The basis of payment for work and materials will be the actual amount of work done and materials furnished. The CONTRACTOR agrees that he will make no claim for damages, anticipated profits, or otherwise on account of any difference between the amounts of work actually performed and materials actually furnished and the estimated amounts thereof.

MP-4 **ASPHALT WORK ITEMS**

MP-4.1.00 **Charge to respond to repairs not ready for restoration**

The work covered by this section will be paid for at the contract price per each occurrence as defined in Item #4 in the Specifications and Details section of the contract.

MP-4.2.00 **Bituminous Pavement Repair and Resurfacing**

This section covers Items 4.2.01 – 4.2.23 as specified on the Schedule of Estimated Quantities & Bid Prices.

Method of Measurement

For Items 4.2.01 through 4.2.04, and 4.2.18 through 4.2.20 the quantity of Bituminous Pavement Repair, and Bituminous Pavement Resurfacing, (as applicable) to be paid for will be the actual number of repairs or resurfacing completed within the square footage areas as defined for each pay item on the bid

Section IX - Measurement and Payment

schedule. Square footage areas for the repairs shall be computed based on the actual trench width and horizontal length measured in place to the nearest 1/10 square foot. The quantities for resurfacing shall be computed based on existing road widths and required taper (as applicable) to the nearest 1/10 square foot.

For Items 4.2.05 through 4.2.08, 4.2.16, 4.2.17 and 4.2.21 through 4.2.23, the quantity of Bituminous Pavement Repair, and Bituminous Pavement Resurfacing, (as applicable) to be paid for will be the square feet of surface area, to the nearest 1/10 square foot. The quantities for repair shall be computed based on the actual trench width and horizontal length measured in place. The quantities for resurfacing shall be computed based on existing road widths and required taper as applicable.

Where pavement, driveways, or other asphalt surfacing of whatever nature have been removed by the CONTRACTOR beyond the limits called for in the specifications or as set by the DISTRICT, or have been damaged through negligence or carelessness of the CONTRACTOR's forces, they shall be replaced in accordance with these specifications at the CONTRACTOR's expense.

Basis of Payment

For Items 4.2.01 through 4.2.04 and 4.2.18 through 4.2.20, the quantity of Bituminous Pavement Repair and Bituminous Pavement Resurfacing shall be paid for at the contract unit price per each area as defined in the pay items on the bid schedule.

For Items 4.2.05 through 4.2.08, 4.2.16 and 4.2.17 and 4.2.21 through 4.2.23, the quantity of Bituminous Pavement Repair, and Bituminous Pavement Resurfacing shall be paid for at the contract unit price per square foot.

The contract price shall be full compensation for Bituminous Pavement Repair and Bituminous Pavement Resurfacing complete, including but not limited to pavement cutting, binder, hauling, tack coat, spreading, compaction, and all related construction.

MP 4.3.00

Pavement Marking

This section covers Item 4.3.01 as specified on the Schedule of Estimated Quantities & Bid Prices.

Method of Measurement

The quantity of Pavement Marking to be paid for shall be the actual number of pavement markings properly installed and accepted per the applicable NCDOT, City of Asheville, or other municipality specifications.

Basis of Payment

The number of Pavement Markings shall be paid for at the contract unit price for

Section IX - Measurement and Payment

each marking regardless of the actual size/length at each location. Only one unit price payment will be made for each location of work unless otherwise pre-approved in writing by the DISTRICT.

MP 4.4.00 Hand Formed Asphalt Curb

Method of Measurement

The quantity of Hand Formed Asphalt Curb to be paid for shall be the actual number of linear feet properly installed and accepted.

Basis of Payment

The quantity of Hand Formed Asphalt Curb shall be paid for at the contract unit price per linear foot installed complete, including, but not limited, to installation, excavation, form work, backfill, compaction, restoration of surfaces and all related items as required.

MP-4.6.00 Pavement Milling

This section covers Items 4.6.06 through 4.6.08 on the Schedule of Estimated Quantities & Bid Prices.

Method of Measurement

The quantity of Pavement Milling to be paid for will be the square feet of surface area, to the nearest 1/10 square foot. The quantities shall be computed from the actual width and horizontal length measured in place.

Where pavement, driveways, or other asphalt surfacing of whatever nature have been removed by the CONTRACTOR beyond the limits called for in the plans and specifications or as set by the DISTRICT, or have been damaged through negligence or carelessness of the CONTRACTOR's forces, they shall be replaced in accordance with these specifications at the CONTRACTOR's expense.

Where pavement, driveways, or other asphalt surfacing are removed within the construction limits as specified and with the consent of the DISTRICT, they shall be replaced in accordance with the applicable requirements of these specifications and shall be paid for in the manner specified herein.

Basis of Payment

The quantity of Pavement Milling shall be paid at the contract unit price per square foot, for the depth specified in the bid schedule. The contract price shall be full compensation for pavement milling, complete including, but not limited to, hauling, milling equipment, and all related construction.

Section IX - Measurement and Payment

MP-5 CONCRETE WORK ITEMS

MP-5.1.00 Concrete Sidewalk to Specification

This section covers Items 5.1.01 – 5.2.02 on the Schedule of Estimated Quantities & Bid Prices.

Method of Measurement

The quantity of Concrete Sidewalk to Specification to be paid for shall be the number of square feet properly installed and accepted.

Basis of Payment

The quantity of Concrete Sidewalk to Specification shall be paid for at the contract unit price per square foot installed complete, including, but not limited, to installation, excavation, form work, backfill, compaction, restoration of surfaces and all related items as required.

MP-5.2.00 Concrete Driveway to Specification

Method of Measurement

The quantity of Concrete Driveway to Specification to be paid for shall be the number of square feet properly installed and accepted.

Basis of Payment

The quantity of Concrete Driveway to Specification shall be paid for at the contract unit price per square foot installed complete, including, but not limited to, installation, excavation, form work, backfill, compaction, restoration of surfaces and all related items as required.

MP-5.3.00 Concrete Curb and Gutter to Specification

This section covers items 5.3.01 – 5.3.02 on the Schedule of Estimated Quantities & Bid Prices.

Method of Measurement

The quantity of Concrete Curb and Gutter to Specification to be paid for shall be the actual number of curb and gutter sections properly installed and accepted in accordance with the linear footage guidelines defined on the bid schedule and approved by the DISTRICT.

Basis of Payment

The quantity of Concrete Curb & Gutter to Specification shall be paid for at the contract unit price for each linear footage category as defined on the Bid Schedule that is installed complete, including, but not limited to, installation, excavation,

Section IX - Measurement and Payment

form work, backfill, compaction, restoration of surfaces and all related items as required.

SCHEDULE OF ESTIMATED QUANTITIES AND BID PRICES
FY 2025 RESTORATION OF NON-CITY OF ASHEVILLE ROAD RIGHTS-OF-WAY
FOLLOWING MSD WASTEWATER COLLECTION SYSTEM MAINTENANCE
PROJECT NO. 2002101
METROPOLITAN SEWERAGE DISTRICT OF BUNCOMBE COUNTY

ITEM #	DESCRIPTION	QTY	UNIT	UNIT BID PRICE	TOTAL
MP-4.1.00	Charge to respond to repairs not ready for restoration	1	EA	\$	\$
MP-4.2.01	4" RS or S9.5B Mix (less than 25 square feet)	1	EA	\$	\$
MP-4.2.02	4" I 19.0C Mix (less than 25 square feet) for binder course use only	1	EA	\$	\$
MP-4.2.03	6" RS or S9.5B Mix (Less than 25 square feet) NCDOT specification	2	EA	\$	\$
MP-4.2.04	6" I 19.0C Mix (less than 25 square feet) for binder course use only	1	EA	\$	\$
MP-4.2.05	4" RS or S9.5B Mix (greater than 25 square feet)	50	SF	\$	\$
MP-4.2.06	4" I 19.0C Mix (greater than 25 square feet) for binder course only	100	SF	\$	\$
MP-4.2.07	6" RS or S9.5B Mix (greater than 25 square feet) NCDOT specifications	100	SF	\$	\$
MP-4.2.08	6" I 19.0C Mix (greater than 25 square feet) for binder course only	250	SF	\$	\$
MP-4.2.16	2" Overlay S9.5C (between 0 square feet and 1,000 square feet)	3,000	SF	\$	\$
MP-4.2.17	2" Overlay S9.5C (1,000 square feet and greater)	2,000	SF	\$	\$
MP-4.2.18	2" RS or S9.5C Mix (less than 25 SF)	1	EA	\$	\$
MP-4.2.19	4" RS or S9.5C Mix (less than 25 SF)	30	EA	\$	\$
MP-4.2.20	6" RS or S9.5C Mix (less than 25 SF)	10	EA	\$	\$
MP-4.2.21	2" RS or S9.5C Mix (greater than 25 SF)	1,000	SF	\$	\$
MP-4.2.22	4" RS or S9.5C Mix (greater than 25 SF)	2,500	SF	\$	\$
MP-4.2.23	6" RS or S9.5C Mix (greater than 25 SF)	1,800	SF	\$	\$
MP-4.3.01	Striping / Pavement marking per NCDOT specifications	30	EA	\$	\$
MP-4.4.00	Hand formed RS or S 9.5 B Asphalt Curb to match existing	100	LF	\$	\$
MP-4.6.06	Asphalt Milling	3,000	SF	\$	\$
TOTAL ASPHALT				\$	

SCHEDULE OF ESTIMATED QUANTITIES AND BID PRICES
FY 2025 RESTORATION OF NON-CITY OF ASHEVILLE ROAD RIGHTS-OF-WAY
FOLLOWING MSD WASTEWATER COLLECTION SYSTEM MAINTENANCE
PROJECT NO. 2002101
METROPOLITAN SEWERAGE DISTRICT OF BUNCOMBE COUNTY

ITEM #	DESCRIPTION	QTY	UNIT	UNIT BID PRICE	TOTAL
MP-5.1.01	4" Concrete Sidewalk to specification	25	SF	\$	\$
MP-5.1.02	6" Concrete Sidewalk to specification	350	SF	\$	\$
MP-5.2.02	6" Concrete Driveway to specification	300	SF	\$	\$
MP-5.3.01	Concrete Curb & Gutter less than 5 linear feet to specification	3	EA	\$	\$
MP-5.3.02	Concrete Curb & Gutter more than 5 linear feet to specification	20	LF	\$	\$
TOTAL COST OF SIDEWALK REPAIRS				\$	
GRAND TOTAL OF ASPHALT AND SIDEWALK REPAIRS				\$	
TOTAL WRITTEN BID AMOUNT _____					

PROPOSAL

Date: _____

To: Metropolitan Sewerage District
Buncombe County, North Carolina
Asheville, North Carolina

Ladies and/or Gentlemen:

In response to your request the undersigned Bidder submits the following proposal for constructing the proposed project described and specified in the attached documents titled:

FY 2025 Contract for the Restoration of Non-City of Asheville Road Rights-of-Way Following MSD Wastewater Collection System Maintenance, Project No. 2002101.

1. Bidder proposes and agrees, in event this proposal is accepted, to enter into a contract with the Metropolitan Sewerage District of Buncombe County, North Carolina (herein designated and referred to as the DISTRICT), in the form herein specified, to furnish all materials, equipment, machinery, tools, means of transportation, power and fuel and to perform all labor necessary for or incidental to the construction of the aforementioned improvements, all in complete accordance with the requirements of the attached contract documents, to the entire satisfaction of the DISTRICT, at the unit and/or lump sum prices we have inserted opposite each item of work listed in the accompanying "Schedule of Estimated Quantities and Bid Prices" and/or bid sheet, which is an integral part of this proposal.

2. In submitting this proposal the Bidder understands and agrees that a contract may be awarded for the work as may appear to the interest of the DISTRICT; that the quantities as stated are approximate only and that no claim shall be made against the DISTRICT on account of any excess or deficiency, either absolute or relative, therein; that the estimated quantities will be used as a basis for canvassing and evaluating proposals and for determining the estimated amount of the contract, and that, within the limits of available funds, the DISTRICT reserves the right to increase or decrease the estimated quantities, stated above by such amounts as may be necessary to complete the work, provided, however, that the stated unit prices shall remain firm and unchanged.

3 Bidder hereby declares that the only person or persons interested in this proposal as principal or principals is or are named herein and that no other person than herein mentioned has any interest in this proposal or in the contract to be entered into, that this proposal is made without connection with any other person, company or parties making a proposal, and that this proposal is in all respects fair and made in good faith without collusion or fraud.

4. Bidder acknowledges his/her awareness of the pre-bid meeting held on May 12, 2023 and understands the conditions that may be present at each potential work location; that he/she has examined the specifications for the work and the other contract documents relating thereto and has read all Special Conditions furnished prior to the opening of bids; and that he/she has satisfied himself/herself relative to the work to be performed.

5. Bidder further proposes and agrees, that, if awarded a contract for this project, he/she will commence work immediately on the date stated in a written notice from the DISTRICT to commence work; that he/she will furnish all materials, and perform all labor for the completion of the contract and will complete same, including all accepted alternates thereto, within the time stated.

The DISTRICT reserves the right to issue a penalty of \$200.00 per day for failure to restore the asphalt, as specified in Section VI – Specifications and Details, for each repair left unattended after the first day, excluding overlays.

6. And the Bidder further declares that accompanying this proposal is a certified check or satisfactory bid bond in the sum of five percent (5%) of this proposal, and it is hereby agreed that in case of the withdrawal of this proposal without the consent of the DISTRICT within sixty (60) days after the bid opening, or that in case of failure on the part of the undersigned to execute the contract as aforesaid and to deliver same and the required security for the faithful performance of the contract, (executed in the form annexed hereto) to said DISTRICT within ten days from the date a notice of acceptance of this proposal is given to the undersigned personally, or by mail to the address as herein stated, then the undersigned Bidder will be deemed to have abandoned the contract, and thereupon the amount of such check or bond shall be absolutely due and payable thereunder to the DISTRICT.

7. The bidder understands that the DISTRICT reserves the right to withhold retainage for work undertaken in accordance with NCGS 143-134.1. In such an event, retainage shall be withheld as follows: Five percent (5%) retainage from progress payments until the Project is fifty percent (50%) complete. In accordance with NCGS 143-134.1 the DISTRICT will then retain this constant amount, while retaining no further retainage, until the project is one-hundred percent (100%) complete. If the DISTRICT becomes dissatisfied with performance of the CONTRACTOR after reducing or holding the Five Percent (5%) retainage, the DISTRICT may reinstitute such retainage until the Project has been completed, or may withhold up to two and one-half (2.5) times the value of any incomplete Work.

Nothing in this section shall be deemed to preclude the DISTRICT from withholding full or partial payment for defective Work or Work that has not been fully completed in accordance with the Project Specifications and the Contract Documents, to the satisfaction of the MSD Engineer.

Individual or Firm Name of Bidder

By _____

Title: _____

State License No. _____ Type: _____ Limit: _____ Expiration Date: _____

Bidder's Address: _____

Note: If the Bidder is a corporation give the following information:

State in which it is incorporated _____

Address of Principal Office _____

The Bidder acknowledges receipt of the following addenda:

No.	Date
_____	_____

BIDDER'S REFERENCE PAGE

(Submit with Bid)

The CONTRACTOR shall submit references for street and highway surface restoration on projects of scope equal to or larger than this project which the DISTRICT can verify. Each reference shall be for work actually performed by the Bidder. All references shall pertain to actual surface restoration performed by the Bidder (sub-contractor references are not applicable). Reference work shall have been performed with the manner of application specified herein. A minimum of three (3) verifiable references are required.

ALL REFERENCES WILL BE TREATED AS THE CONTRACTOR'S CONFIDENTIAL BUSINESS INFORMATION. Previous work for the DISTRICT may be used as references.

Complete each item for all 3 references.

Owner/Agency	
Address	
Address	
City, State, Zip	
Contact w/Phone	
Project Description	

Owner/Agency	
Address	
Address	
City, State, Zip	
Contact w/Phone	
Project Description	

Owner/Agency	
Address	
Address	
City, State, Zip	
Contact w/Phone	
Project Description	

Only Contractors experienced in this type of work will be considered. Failure to provide sufficient verifiable references will result in rejection of this bid.

BID BOND
(FORM)

Date of Execution
of this Bond: _____

Name and Address
of Principal (Bidder): _____

Name and Address
of Surety: _____

Name and Address
of Oblige: Metropolitan Sewerage District of Buncombe County, NC
2028 Riverside Drive - Asheville, NC 28804

Amount of Bond: Five Percent (5%) of attached bid dollars

Bid and Proposal
Dated: _____ for the **FY 2025 Contract for the Restoration of Non-City of Asheville Road Rights-of-Way Following MSD Wastewater Collection System Maintenance, Project No. 2002101.**

KNOW ALL MEN BY THESE PRESENTS, That we, the PRINCIPAL above named and SURETY above names who is duly licensed to act as SURETY in the State of North Carolina, are held and firmly bound unto the METROPOLITAN SEWERAGE DISTRICT OF BUNCOMBE COUNTY, a body politic and corporate of the State of North Carolina, as Obligee, in the penal sum of FIVE PERCENT (5%) of the amount bid in the bid and proposal above described in lawful money of the United States of America, for the payment of which, well and truly to be made we bind ourselves, our heirs, executors, administrators, successors and assigns, jointly and severally, firmly by these presents.

NOW, THEREFORE, THE CONDITION OF THIS OBLIGATION is such, that if the Principal shall be awarded the contract for which the bid and proposal above described is submitted and shall execute the contract, give bond for the faithful performance of the contract, and give bond for the payment to all persons supplying labor and material in the prosecution of the work provided for in said contract, within ten (10) days after the award of the same to the Principal above named, then this obligation shall be null and void; but if the Principal above names fails to so execute such contract and give performance bond and payment bond as required by Section 129 of Chapter 143 of the General Statutes of North Carolina, as amended, and Article 3 of Chapter 44-A of the General Statutes of North Carolina, as amended, the Surety shall, upon demand, forthwith pay to the OBLIGEE the amount of this bond set forth above.

IN WITNESS WHEREOF, the Principal above names and the Surety above names have executed this instrument under their several seals on the date set forth above.

WITNESS:

(Proprietorship or Partnership)

ATTEST: (Corporation)

BY: _____

TITLE: _____
(Corporate Secretary or Assistant Secretary only)

WITNESS:

Principal (name of individual, individual and trade name, partnership, corporation or joint venture)

BY: _____

TITLE: _____
(owner, partner, office held in corporation, joint venture)

(Corporate Seal)

Surety (name of Surety Company)

BY: _____

TITLE: Attorney-in-Fact
(Corporate Seal of Surety)

Address of Attorney-in-Fact)

NOTICE OF AWARD

TO:

PROJECT: FY 2025 Contract for the Restoration of Non-City of Asheville Road Rights-of-Way Following MSD Wastewater Collection System Maintenance, Project No. 2002101

The DISTRICT has considered the BID submitted by you for the above-described WORK in response to its Advertisement for Bid and Instruction to Bidders.

You are hereby notified that your BID has been accepted for items in the amount of

You are required by the Instruction to Bidders to execute the Agreement and furnish the required CONTRACTOR's Performance Bond, Payment Bond and Certificates of Insurance within ten (10) calendar days from the date of receipt of this Notice by you.

If you fail to execute said agreement and to furnish said BONDS within ten (10) days from the date of your receipt of this NOTICE, said DISTRICT will be entitled to consider all your rights arising out of the BONDS. The DISTRICT will be entitled to such other rights as may be granted by law.

You are required to return an acknowledged copy of this NOTICE OF AWARD to the DISTRICT.

Dated this _____ day of _____, 2024.

Metropolitan Sewerage District
of Buncombe County, North Carolina

By: _____
W. Hunter Carson, P.E.
Director of Engineering

ACCEPTANCE OF NOTICE

Receipt of the above NOTICE OF AWARD is hereby acknowledged by _____
_____ this the _____ day of _____, 2024.

By: _____

Title: _____

AGREEMENT FORM

THIS AGREEMENT, made and entered into this the _____ day of _____, 2024, by and between the **Metropolitan Sewerage District of Buncombe County, North Carolina**, hereinafter referred to as the DISTRICT and _____ hereinafter referred to as the CONTRACTOR.

WITNESSETH:

That the parties hereto do mutually agree as follows:

1. The CONTRACTOR will furnish all materials, equipment, supplies, tools, power, fuel and services and perform all labor necessary for contract for services for the restoration of streets and highway rights-of-way following maintenance performed by the Metropolitan Sewerage District of Buncombe County, North Carolina on the wastewater collection system and will construct same in strict conformity with the terms and conditions set forth in the following named documents which are hereto attached and made a part of this contract:

FY 2025 Contract for the Restoration of Non-City of Asheville Road Rights-of-Way Following MSD Wastewater Collection System Maintenance, Project No. 2002101

Notice of Contractors, Special Conditions and Details, Proposal and Bid Sheets, Notice of Award, Agreement, Performance Bond, Payment Bond, Insurance Form, Notice to Proceed and Payment Request forms.

2. The DISTRICT will pay to the CONTRACTOR, on faithful performance of his undertakings hereunder, in lawful money of the United States, the respective unit prices set forth in the aforementioned bid proposal for each unit of work performed or installed by the CONTRACTOR; the estimated sum total of all payments hereunder being:
3. The DISTRICT will make payments to the CONTRACTOR as specified in the Specifications.
4. Within a period of 30 days after completion of the work, the DISTRICT will make a final and complete payment in full to the CONTRACTOR on account of this contract; provided that, during said 30 day period, the CONTRACTOR has submitted to the DISTRICT satisfactory written evidence that all payrolls and other costs incurred by the CONTRACTOR in connection with the work have been paid in full; otherwise final payment will be made only after such evidence has been submitted.
5. The CONTRACTOR will commence the work on or as of the date set in a notice from the DISTRICT to proceed with the work, will prosecute same diligently and continuously until completed, and will complete same in conformity with the stated requirements.
6. The CONTRACTOR shall be solely and completely responsible for safety at the job site.
7. As a condition of this contract, CONTRACTOR agrees and warrants and represents that it will comply with the requirements of Article 2 of Chapter 64 of the North Carolina General Statutes. If CONTRACTOR utilizes a subcontractor to perform any part of the work included in the Contract, CONTRACTOR shall require the subcontractor to comply with the requirements of Article 2 of Chapter 64 of the North Carolina General Statutes.

IN WITNESS WHEREOF, the parties have executed this contract on the day and date first above written in three (3) original counterparts.

WITNESS:

**METROPOLITAN SEWERAGE DISTRICT
OF BUNCOMBE COUNTY, N.C.**

By _____
Thomas E. Hartye, P.E.
General Manager (SEAL)

WITNESS:

CONTRACTOR

(Proprietorship or Partnership)

By _____
Title _____

**CERTIFICATE OF SECRETARY
OF CORPORATION:**

I, _____ certify that I am the Secretary of the Corporation named as Contractor herein; that _____, who signed this contract on behalf of the Contractor, was then _____ of said Corporation; that said contract was duly signed for and on behalf of said Corporation by authority of its governing body and is within the scope of its corporate powers.

SECRETARY

(Corporate Seal)

W. Scott Powell, MSD Finance Director

“This instrument has been pre-audited in the manner required by the Local Government Budget and Fiscal Control Act”

PERFORMANCE BOND
(Form)

Date of Execution
of this Bond: _____

Name and Address of
Principal (Contractor): _____

Name and Address
of Surety: _____

Name and Address of
Contracting Body: **Metropolitan Sewerage District of
Buncombe County, North Carolina
2028 Riverside Drive
Asheville, North Carolina 28804**

Amount of Bond: _____

Contract: That certain contract by and between the Principal and the
Contracting Body above named dated _____ for the
**FY 2025 Contract for the Restoration of Non-City of Asheville Road
Rights-of-Way Following MSD Wastewater Collection System
Maintenance, Project No. 2002101.**

KNOW ALL MEN BY THESE PRESENTS, That we, the PRINCIPAL and SURETY above named, are held and firmly bound unto the above named Contracting Body, hereinafter called the Contracting Body, in the penal sum of the amount stated above for the payment of which sum well and truly to be made, we bind ourselves, our heirs, executors, administrators, and successors, jointly and severally, firmly by these presents.

THE CONDITION OF THIS OBLIGATION IS SUCH, that whereas the Principal entered into a certain contract with the Contracting Body, as identified and shown above and hereto attached.

NOW, THEREFORE, if the Principal shall well and truly perform and fulfill all the undertakings, covenants, terms, conditions, and agreements of said contract during the original term of said contract and any extensions thereof that may be granted by the Contracting Body, with or without notice to the Surety, and during the life of any guaranty required under the contract, and shall also well and truly perform and fulfill all the undertakings, covenants, terms, conditions, and agreements of any and all duly authorized modification of the contract that may hereafter be made, notice of which modifications to the Surety being hereby waived, then, this obligation to be void; otherwise to remain in full force and virtue.

THIS PERFORMANCE BOND is made and given pursuant to the requirements and provisions of Section 129 of Chapter 143 of the General Statutes of North Carolina and pursuant to Article 3 of Chapter 44-A of the General Statutes of North Carolina, and each and every provision set forth and contained in Article 3 of Chapter 44-A of the General Statutes of North Carolina is incorporated herein, made a part hereof, and deemed to be conclusively written into this Bond.

IN WITNESS WHEREOF, the principal and surety parties have executed this instrument under their several seals on the date indicated above, the name and corporate seal of each corporate party being hereto affixed and these presents duly signed by its undersigned representative, pursuant to authority of its governing body.

Principal (name of individual, Individual and trade name, partnership, corporation or joint venture)

WITNESS:

(Proprietorship or Partnership)

BY: _____ (SEAL)

TITLE: _____
(owner, partner, office held in corporation, joint venture)

ATTEST: (Corporation)

(Corporate Seal)

BY _____

TITLE: _____
(Corporate Secretary or Assistant Secretary only)

Surety (name of Surety Company)

WITNESS:

BY: _____

TITLE: Attorney-in-Fact

(Corporate Seal of Surety)

(Address of Attorney-in-Fact)

PAYMENT BOND
(Form)

Date of Execution
of this Bond:

Name and Address of
Principal (Contractor):

Name and Address
of Surety:

Name and Address of
Contracting Body:

**Metropolitan Sewerage District of
Buncombe County, North Carolina
2028 Riverside Drive
Asheville, North Carolina 28804**

Amount of Bonds:

Contract:

That certain contract by and between the Principal and the Contracting Body above named dated _____ for the **FY 2025 Contract for the Restoration of Non-City of Asheville Road Rights-of-Way Following MSD Wastewater Collection System Maintenance, Project No. 2002101.**

KNOW ALL MEN BY THESE PRESENTS, That we, the PRINCIPAL and SURETY above named, are held and firmly bound unto the above named Contracting Body, hereinafter called the Contracting Body, in the penal sum of the amount stated above for the payment of which sum well and truly to be made, we bind ourselves, our heirs, executors, administrators, and successors, jointly and severally, firmly by these presents.

THE CONDITION OF THIS OBLIGATION IS SUCH, that whereas the Principal entered into a certain contract with the Contracting Body, as identified and shown above and hereto attached.

NOW THEREFORE, if the Principal shall promptly make payment to all persons supplying labor and material in the prosecution of the work provided for in said contract, and any and all duly authorized modifications and extensions of time of said contract that may hereafter be made, notice of which modifications and extensions of time to the surety being hereby waived, then this obligation to be void; otherwise to remain in full force and virtue.

THIS PAYMENT BOND is made and given pursuant to the requirements and provisions of Section 129 of Chapter 143 of the General Statutes of North Carolina and pursuant to Article 3 of Chapter 44-A of the General Statutes of North Carolina, and each and every provision set forth and contained in Article 3 of Chapter 44-A of the General Statutes of North Carolina is incorporated herein, made a part hereof, and deemed to be conclusively written into this Bond.

IN WITNESS WHEREOF, the principal and surety parties have executed this instrument under their several seals on the date indicated above, the name and corporate seal of each corporate party being hereto affixed and these presents duly signed by its undersigned representative, pursuant to authority of its governing body.

Principal (name of individual, individual and trade name, partnership, corporation or joint venture)

WITNESS:

BY: _____ (SEAL)

TITLE: _____
(owner, partner, office held in corporation, joint venture)

ATTEST: (Corporation)

BY: _____

(Corporate Seal)

TITLE: _____
(Corporate Secretary or Assistant Secretary only)

Surety (name of Surety Company)

WITNESS:

BY: _____

TITLE: Attorney-in-Fact
(Corporate Seal of Surety)

(Address of Attorney-in-Fact)

Section XVI - Certificate of Insurance

DATE OF ISSUANCE

To the Metropolitan Sewerage District of Buncombe County, North Carolina. The subscribing insurance company certifies that insurance of the kinds and types and for limits of liability covering the work herein designated has been procured by and furnished on behalf of the insured contractor/vendor listed below:

NAME AND ADDRESS OF PRODUCER:	CERTIFICATE HOLDER: METROPOLITAN SEWERAGE DISTRICT OF BUNCOMBE COUNTY, NORTH CAROLINA 2028 RIVERSIDE DRIVE ASHEVILLE, NORTH CAROLINA 28804 TELEPHONE NO. (828) 254-9646
NAME AND ADDRESS OF INSURED:	COMPANIES AFFORDING COVERAGE
	COMPANY LETTER "A":
	COMPANY LETTER "B":
	COMPANY LETTER "C":
	COMPANY LETTER "D":
	COMPANY LETTER "E":

Description of Work & Location FY 2025 Contract for Paving Restoration

CO. LTR	TYPE OF INSURANCE	POLICY NUMBER	POLICY EFFECTIVE DATE (MM/DD/YY)	POLICY EXPIRATION DATE (MM/DD/YY)	LIMITS (IN THOUSANDS)
	GENERAL LIABILITY _ Commercial General Liability _ Claims Usage _ Occurrence _ Owner & Contractor Protective _ _____ _ _____				General Aggregate \$ 2,000 Products-Comp/Ops Aggregate \$ 1,000 Personal & Advertising Injury \$ 1,000 Each Occurrence \$ 1,000 Fire Damage (any one fire) \$ 50 Medical Expense (any one person) \$ 5
	AUTOMOBILE LIABILITY _ Any Auto _ All owned Autos _ Scheduled Autos _ Hired Autos _ Non-Owned Autos _ Garage Liability _ _____				Combine Single Limit \$ 1,000 Bodily Injury (per person) \$ Bodily Injury (per accident) \$ Property Damage \$
	EXCESS LIABILITY _ Umbrella Form _ Other Than Umbrella Form				Each Occurrence \$ 1,000 Aggregate \$ 1,000
	WORKERS' COMPENSATION AND EMPLOYERS' LIABILITY				STATUTORY (North Carolina) (Each Accident) \$ 100 (Disease-Policy Limit) \$ 500 (Disease-Each Employee) \$ 100
	OTHER				

UNDER GENERAL LIABILITY POLICY OR POLICIES: Y N

1. Does property damage liability insurance shown include coverage for XC and U hazards? _____
2. Is occurrence basis coverage provided under property damage liability? _____
3. Does Personal Injury Liability Insurance include coverage for personal injury sustained by any person as a result of an offense directly or indirectly related to the employment of such person by the insured? _____
4. Is coverage provided for Contractual Liability (including indemnification provision) assumed by insured? _____
5. The Metropolitan Sewerage District of Buncombe County, North Carolina is named as additionally insured? _____
6. Is Broad Form Property Damage Coverage provided for this project? _____

CANCELLATION / EXPIRATION: The subscribing company hereby agrees that thirty (30) days written notice shall be given to the Metropolitan Sewerage District of Buncombe County, North Carolina before any policy referred to herein is changed or canceled. In addition, immediate notice shall be given by the subscribing company to the Metropolitan Sewerage District of Buncombe County, North Carolina if any policy is not renewed by the insured.

Name of Insurance Company Authorized to do Business in North Carolina _____ Address _____

Signature of Authorized Representative _____ Date of Signature _____

NOTICE TO PROCEED

TO:

DATE: _____

**FOR: FY 2025 Contract for the Restoration of Non-City of Asheville Road Rights-of-Way
Following MSD Wastewater Collection System Maintenance, Project No. 2002101**

You are hereby notified to commence WORK in accordance with the Agreement dated _____
_____, on or before July 1, 2024. The contract time shall be for one (1) year and terminate on June 30,
2025.

**METROPOLITAN SEWERAGE DISTRICT
OF BUNCOMBE COUNTY, NORTH CAROLINA**

BY: _____

W. Hunter Carson, P.E.
Director of Engineering

ACCEPTANCE OF NOTICE

Receipt of the above **NOTICE TO PROCEED** is hereby acknowledged by _____

this the _____ day of _____, 2024.

BY: _____

TITLE: _____

APPLICATION FOR PAYMENT

THE METROPOLITAN SEWERAGE DISTRICT OF BUNCOMBE COUNTY

**FY 2025 Contract for the Restoration of Non-City of Asheville Road Rights-of-Way
Following MSD Wastewater Collection System Maintenance, Project No. 2002101**

INVOICE NO.: _____

DATE NOTICE TO PROCEED: _____

CONTRACTOR: _____

ADDRESS: _____

CONTRACT: _____

ORIGINAL CONTRACT AMOUNT: \$ _____

APPROVED CHANGE ORDER AMOUNT: \$ _____

REVISED CONTRACT AMOUNT: \$ _____

TOTAL WORK COMPLETED PRIOR INVOICES: \$ _____

TOTAL WORK EARNED THIS INVOICE: \$ _____

TOTAL WORK COMPLETED TO DATE ALL INVOICES: \$ _____

LESS RETAINAGE \$ 0* _____

(*DISTRICT reserves the right to withhold retainage per NCGS 143-134.1)

TOTAL WORK TO DATE LESS RETAINAGE: \$ _____

LESS PREVIOUS PAYMENTS: \$ _____

CURRENT PAYMENT DUE: \$ _____

CONTRACTOR: _____

NAME	TITLE	DATE

APPROVAL:

SYSTEM SERVICES CONSTRUCTION MANAGER DATE

CONSTRUCTION DIRECTOR DATE

AFFIDAVIT OF PAYMENT OF CLAIMS

BY: _____

This day _____, personally appeared before, _____
_____, a Notary Public in and for the County of _____, State of
and being by me first duly sworn, states that all subcontractors and suppliers of labor and materials have
been paid all sums due them as of _____ (date), for work performed or materials
furnished in the performance of the contract between Metropolitan Sewerage District (DISTRICT), and
_____, CONTRACTOR, for the construction of the **FY
2025 Contract for the Restoration of Non-City of Asheville Road Rights-of-Way Following MSD
Wastewater Collection System Maintenance, Project No. 2002101**, or arrangements have been made
by the CONTRACTOR satisfactory to such subcontractors and suppliers with respect to the payments of
such sums as may be due them by the CONTRACTOR.

(CONTRACTOR)

By: _____
Title: _____

SWORN TO AND SUBSCRIBED before me this the _____ day of _____, 20____.

My Commission Expires

Notary Public

(SEAL)

STATE AND COUNTY SALES/USE TAX CERTIFICATION

I, _____, of _____

hereby certify that the firms cited have been paid the North Carolina Sales Tax and the Buncombe County Tax, as shown on the materials purchased by us, and that these materials became a part of the **FY 2025 Contract for the Restoration of Non-City of Asheville Road Rights-of-Way Following MSD Wastewater Collection System Maintenance, Project No. 2002101**, North Carolina, through

_____.

Please see attached...

Name of Firm: _____

Signature: _____

Title: _____

SWORN TO AND SUBSCRIBED before me, this the _____ day of _____, 20__.

My Commission Expires

Notary Public

(Seal)

CONTRACTOR NAME _____

PROJECT NAME AND NO. _____

INVOICE NO.	INVOICE DATE	VENDOR NAME	SUBTOTAL AMOUNT OF INVOICE	SALES TAX STATE	SALES TAX COUNTY	TOTAL TAX	TOTAL INVOICE
TOTALS MUST BE SHOWN							

(PAID INVOICES ATTACHED IN ORDER)