

Depths of Paving Courses for Pavement Repairs Not Requiring Binder			
Classification	Base Course	Binder	Surface Course
Light Duty Commercial Drive	8" ABC compacted to 100% standard proctor	No binder needed	2" S9.5C compacted to 90% of maximum lab density
Residential Drive	8" ABC compacted to 100% standard proctor	No binder needed	2" S9.5C compacted to 90% of maximum lab density

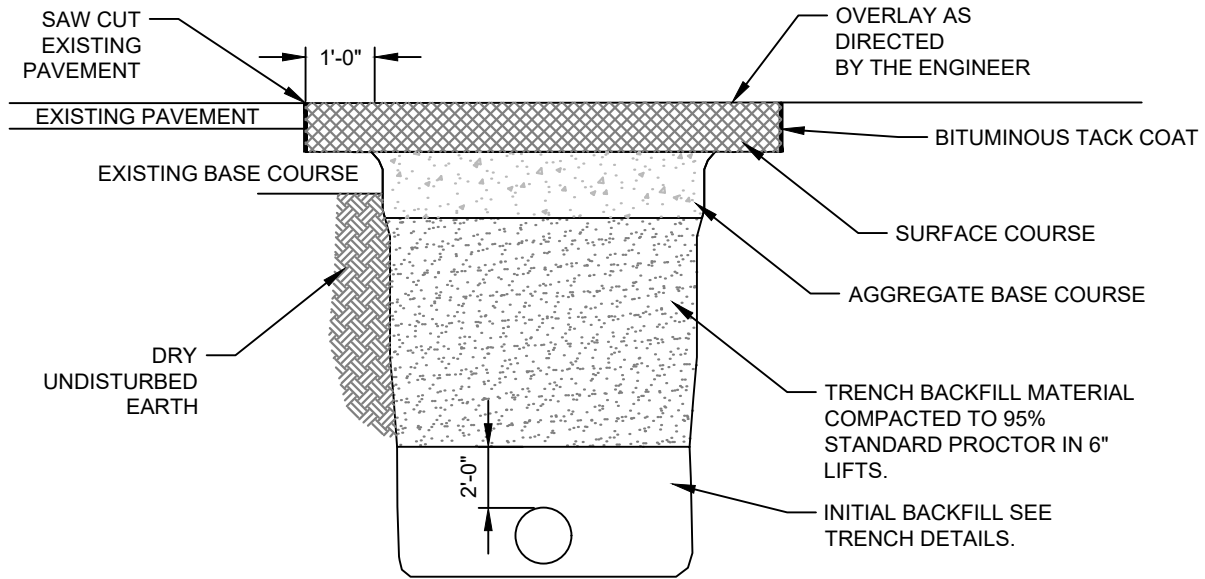

PRIVATE DRIVE AND PARKING LOT PAVEMENT REPAIR
(IN AREAS OF NON-HEAVY DUTY TRAFFIC)
N.T.S.

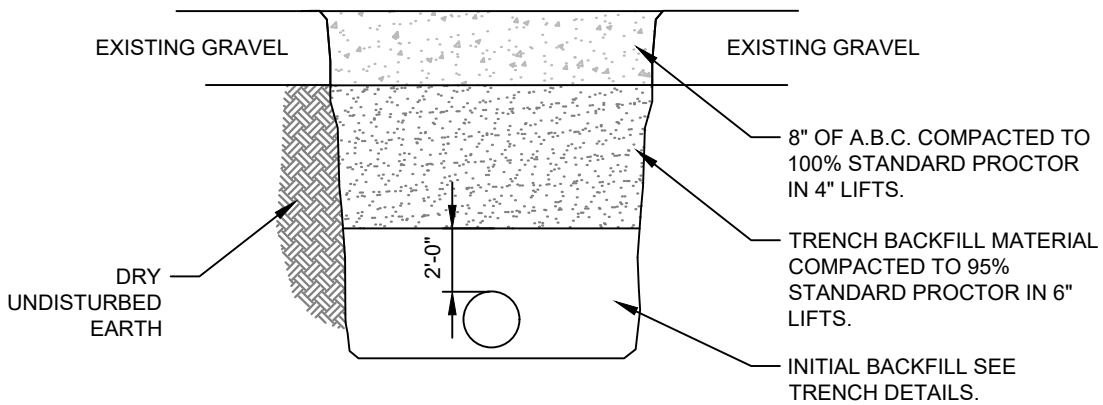

GRAVEL SURFACE REPAIR
N.T.S.

NOTES:

1. EDGES ARE TO BE SAW CUT WITH A CONCRETE SAW TO A NEAT SQUARED EDGE, AND BROOMED CLEAN OF DUST PRIOR TO APPLICATION OF TACK.
2. PAVEMENT REPAIR DETAIL SHALL BE USED FOR ALL BITUMINOUS SURFACES WHICH ARE NOT UNDER CONTROL OF THE N.C.D.O.T. OR BILTMORE FOREST.

STANDARD DETAIL	
Metropolitan Sewerage District of Buncombe County, North Carolina	
PERMANENT PAVEMENT & GRAVEL SURFACE REPAIR	
DATE APPROVED: MARCH 2017	4.08 - 02